

Computational Linguistics and Talking Robots

ROLAND HAUSSER
Computational Linguistics
Universität Erlangen Nürnberg
Germany

rrh@linguistik.uni-erlangen.de



2011

CLUE

Table of Contents

1. Introduction: How to Build a Talking Robot	6
1.1 Universals	6
1.2 Declarative Specification	9
1.3 Comparison with Other Systems	11

Part I. Five Mysteries of Natural Language Communication

2. Mystery Number One: Using Unanalyzed External Surfaces	15
2.1 Structure of Words	15
2.2 Modality-Dependent Unanalyzed External Surfaces	16
2.3 Modality Conversion in the Speak and Hear Modes	19
2.4 Automatic Word Form Recognition	21
2.5 Backbone of the Communication Cycle	22
3. Mystery Number Two: Natural Language Communication Cycle	24
3.1 Choosing the Data Structure	24
3.2 Representing Content	25
3.3 Hear, Think, and Speak Modes	29

3.4 Algorithm of LA-Grammar	31
3.5 Relating Kinds of Proplets to Traditional Parts of Speech	35
3.6 Linguistic Relativism vs. Universal Grammar	40
4. Mystery Number Three: Memory Structure	41
4.1 Database Schema of a Word Bank	41
4.2 Retrieving Answers to Questions	42
4.3 Reference as a Purely Cognitive Procedure	43
4.4 Coreference-by-Address	46
4.5 Component Structure and Functional Flow	48
4.6 Embedding the Cycle of Communication into the Agent	53
5. Mystery Number Four: Autonomous Control	56
5.1 Pinball Machine Model of Cognition	56
5.2 DBS Inferences for Maintaining Balance	58
5.3 DBS Inferences for Meaning and Event Relations	61
5.4 Subactivation and Intersection	64
5.5 Analogical Models for Problem Solving	66
5.6 Subjunctive Transfer and Managing the Data Stream	70
6. Mystery Number Five: Learning	71
6.1 Fixed Behavior Agents	71

6.2 Guided Patterns to Expand a Fixed Behavior Repertoire	77
6.3 Transition from Fixed to Adaptive Behavior	80
6.4 Upscaling from Coordination to Functor-Argument	83
6.5 Schema Derivation and Hierarchy Inferencing	86
6.6 Natural vs. Artificial Language Learning	93

Part II. The Coding of Content

7. Compositional Semantics	101
7.1 Forms of Graphical Representation	101
7.2 Absorption and Precipitation of Function Words	103
7.3 Deriving DBS Graphs from Sets of Proplets	108
7.4 Producing Natural Language Surfaces from Content	112
7.5 Transparent vs. Opaque Functor-Argument	120
7.6 Possible and Actual Semantic Relations of Structure	125
8. Simultaneous Amalgamation	131
8.1 Intuitive Outline of LA-Content	131
8.2 Formal Definition of LA-Content	136
8.3 Linear Complexity of LA-Content	140

8.4	Infinitive Content Constructions	142
8.5	Selectional Constellations of Elementary Signatures	146
8.6	Appear, Promise, and Persuade Class Infinitives	150
9.	Graph Theory	157
9.1	Content Analysis as Undirected and Directed Graphs	157
9.2	Extrapositional Coordination	163
9.3	Sharing in Relative Clauses	168
9.4	Unbounded Dependencies	172
9.5	Subject Gapping and Verb Gapping	174
9.6	Object Gapping and Noun Gapping	177
10.	Computing Perspective in Dialogue	182
10.1	Agent's STAR-0 Perspective on Current Content	182
10.2	Speaker's STAR-1 Perspective on Stored Content	184
10.3	Hearer's STAR-2 Perspective on Language Content	186
10.4	Dialogue with a WH Question and Its Answer	190
10.5	Dialogue with a Yes/No Question and Its Answer	197
10.6	Dialogue with Request and Its Fulfillment	200
11.	Computing Perspective in Text	206
11.1	Coding the STAR-1 in Written Text	206

11.2 Direct Speech in Statement Dialogue	207
11.3 Indexical vs. Coreferential Uses of 3rd Pronouns	210
11.4 Langacker-Ross Constraint for Sentential Arguments	212
11.5 Coreference in Adnominal Sentential Modifiers	218
11.6 Coreference in Adverbial Sentential Modifiers	225

Part III. Final Chapter

12. Conclusion	230
12.1 Level of Abstraction	230
12.2 Evolution	231
12.3 Semantics	232

1. Introduction: How to Build a Talking Robot

1.1 Universals

1.1.1 Universals of natural language communication

1. The cycle of natural language communication is based on the *hear*, the *think*, and the *speak* modes of cognitive agents.
2. In communication, expressions of natural language are interpreted relative to an agent-internal *context* of use.
3. All natural languages have a *time-linear* structure, i.e., linear like time and in the direction of time.
4. All natural languages use the three kinds of sign *symbol*, *index*, and *name*, each with its own mechanism of reference.
5. All natural languages use *coordination* and *functor-argument* to compose content at the *elementary*, the *phrasal*, and the *clausal* level.
6. All natural languages distinguish parts of speech, e.g., *noun* (object, argument), *verb* (relation, functor), and *adjective* (property, modifier).
7. All natural languages have the sentential moods *declarative*, *interrogative*, and *imperative*.

1.1.2 Requirements of a grounded artificial agent

In order to be grounded, a cognitive agent requires a body with

1. *interfaces*
for recognition and action, based on
2. a *data structure*
for representing content,
3. a *database*
for storing and retrieving content,
4. an *algorithm*
for reading content into and out of the database as well as for processing content, and combined into
5. a *software program*
which models the cycle of natural language communication as well as language and nonlanguage inferencing.

1.1.3 The Conversion Universals of DBS

1. From the agent's *speak* mode to its *hear* mode and back,
2. from a *modality-free* to a *modality-dependent* representation of the surface in the speak mode and back in the hear mode, in word form production (synthesis) and recognition,
3. from *order-free content* to *ordered surfaces* in the speak mode and back in the hear mode, and
4. from the STAR-0 to the STAR-1 perspective in the speak mode and from the STAR-1 to the STAR-2 perspective in the hear mode.

1.1.4 Internal structure of the DBS Conversion Universals

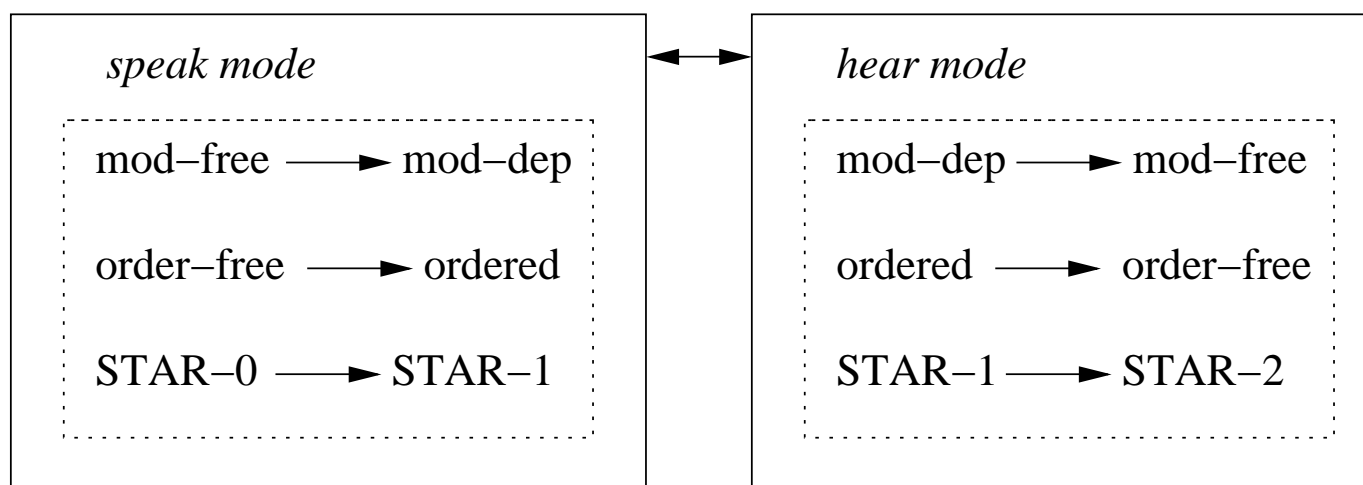

1.2 Declarative Specification

1.2.1 Advantages of proplets

1. Flat ordered feature structures are easier to read and computationally more efficient than recursive feature structures with unordered attributes.
2. Flat ordered feature structures provide for easy schema derivation and for easy pattern matching.
3. The combination of a proplet's core and `prn` value provides a natural primary key for storage in and retrieval from memory.
4. Coding the semantic relations between proplets as addresses makes proplets order-free and therefore amenable to the needs of one's database.
5. The semantic relations between proplets enable time-linear navigation along those relations, reintroducing order and serving as the selective activation of content, as needed in language production and inferencing.

1.2.2 Comparison of language, content, and pattern proplets

German proplet

[sur: Hund]
noun: dog
cat: m-g
sem: sg
fnc: bark
mod: old
prn: 23]

French proplet

[sur: chien]
noun: dog
cat: sn m
sem: sg
fnc: bark
mod: old
prn: 24]

content proplet

[sur:
noun: dog
cat: sn
sem: sg
fnc: bark
mod: old
prn: 25]

pattern proplet

[sur:
noun: α
cat: sn
sem: sg
fnc:
mod:
prn: K]

1.3 Comparison with Other Systems

1.3.1 Summary of differences between DBS and other systems

1. Derivation Order:

The parsing algorithm of DBS, i.e., LA-grammar, uses a strictly time-linear derivation order to compute *possible continuations*. The derivations of Phrase Structure Grammars and Categorical Grammars, in contrast, are partially ordered and compute *possible substitutions*. As a consequence, the application of LA-grammar to natural language has been shown to be of linear complexity, while the complexity of the other grammar formalisms is either polynomial but empirically inadequate (context-free), or computationally intractable ranging from context-sensitive (exponential) to recursively enumerable (undecidable).

2. Ontology:

In DBS, the model of natural language communication is located inside the speaker-hearer as a software machine attached to the agent's external and internal interfaces. In Truth-Conditional Semantics, in contrast, the speaker-hearer is part of a set-theoretic model, and nonprocedural metalanguage definitions are used to connect the language expressions directly to referents in the model. As a consequence, DBS is designed for a talking robot, while Truth-Conditional Semantics is not.

3. **Elementary Meaning:**

In DBS, the agent's basic recognition and action procedures are reused as the elementary meanings of language. In Truth-Conditional Semantics, in contrast, elementary meanings are defined in terms of their truth-conditions relative to a set-theoretic model. As a consequence, the meanings in DBS have concrete realizations in terms of software and hardware procedures, while those of Truth-Conditional Semantics do not.

4. **Database:**

In DBS, the content derived in the hear mode or by inferencing is stored in a *content-addressable* memory, called Word Bank. Most current applications, in contrast, use a *coordinate-addressable* database, for example, an RDBMS, if they use a database at all. The crucial property of content-addressable memories is that they are good for content which is written once and never changed. Given that a cognitive agent is constantly changing, this seems to be a paradoxical quality. It turns out, however, that it is the no-rewrite property which allows for a simple, powerful definition of inferences in DBS.

5. **Data Structure:**

DBS uses flat (non-recursive) feature structures with ordered attributes. Current systems of Nativism, in contrast, use recursive feature structures with unordered attributes to model “constituent structure” trees. Flat feature structures with ordered attributes are of superior computational efficiency for a wide range of operations, such as pattern matching, which is ubiquitous in Database Semantics.

6. **Intention**

DBS reconstructs the phenomenon of intention as part of an autonomous control designed to maintain the agent in a state of balance. This is in contrast to other schools of linguistics and philosophy who refer eclectically to Grice whenever the need arises, but are oblivious to the fact that Grice's elementary, atomic, presupposed notion is of little use for the computational reconstruction of intention and, by Grice's own definition, of meaning in a cognitive agent.

7. **Perspective**

The speak and the hear modes in the agent-oriented approach of DBS provide the foundation for modeling the perspectives of the speaker/writer and the hearer/reader in dialogue/text. They are (i) the perspective of an agent recording a current situation as a content, (ii) a speaker's perspective on a stored content, and (iii) the hearer's perspective on a content transmitted by natural language. In DBS, the computation of these perspectives is based on (i) suitable inferences and (ii) the values of the agent's STAR parameters, for **S**pace, **T**ime, **A**gent, **R**ecipient.

Part I.

Five Mysteries of Natural Language Communication

2. Mystery Number One: Using Unanalyzed External Surfaces

2.1 Structure of Words

2.1.1 Informal examples showing basic word structure

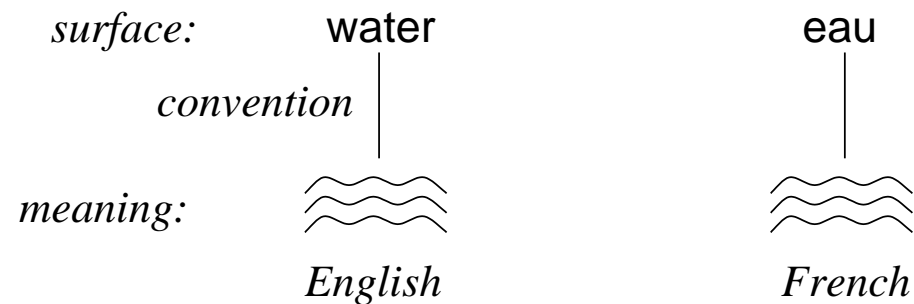

2.1.2 Tasks of learning the words of a foreign language

- learning to recognize and produce the foreign surfaces in the modalities of spoken and written language, and
- learning the conventional connections between the foreign surfaces and meanings familiar from one's first language.

2.2 Modality-Dependent Unanalyzed External Surfaces

2.2.1 Production and recognition of a word

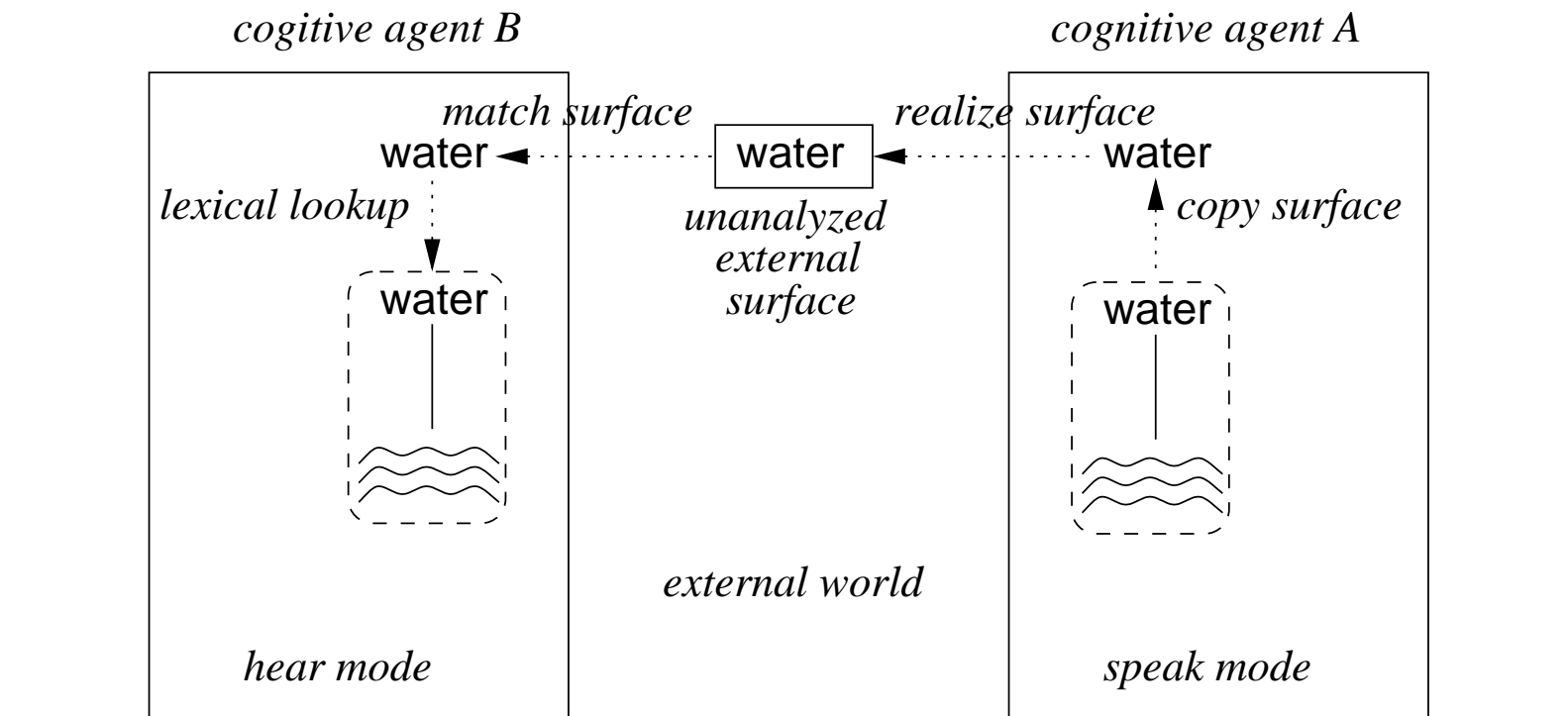

2.2.2 The First Mechanism of Communication (MoC-1)

MoC-1 Natural language communication relies on modality-dependent *external surfaces* which are linguistically unanalyzed in that they have neither meaning nor any grammatical property.

2.2.3 Functional model of natural language communication

A functional model of natural language communication requires

1. a set of cognitive agents each with (i) a body, (ii) external interfaces for recognition and action, and (iii) a memory for the storage and processing of content,
2. a set of external language surfaces which can be recognized and produced by these agents by means of their external interfaces using pattern matching,
3. a set of agent-internal (cognitive) surface-meaning pairs established by convention and stored in memory, whereby the internal surfaces correspond to the external ones, and
4. an agent-internal algorithm which constructs complex meanings from elementary ones by establishing semantic relations between them.

2.2.4 Forms of communication without natural language

- endocrine messaging by means of hormones,
- exocrine messaging by means of pheromones, for example in ants, and
- the use of samples, for example in bees communicating a source of pollen.

2.2.5 Advantages following from MoC-1

1. The modality-free internal meanings attached to the internal surfaces are not restricted by the modality of the external surfaces.
2. The modality-dependent external surfaces are much better suited for (i) content transfer and (ii) agent-external long-term storage than the associated agent-internal modality-free meanings.

2.3 Modality Conversion in the Speak and Hear Modes

2.3.1 INTER-AGENT COMMUNICATION USING SPEECH

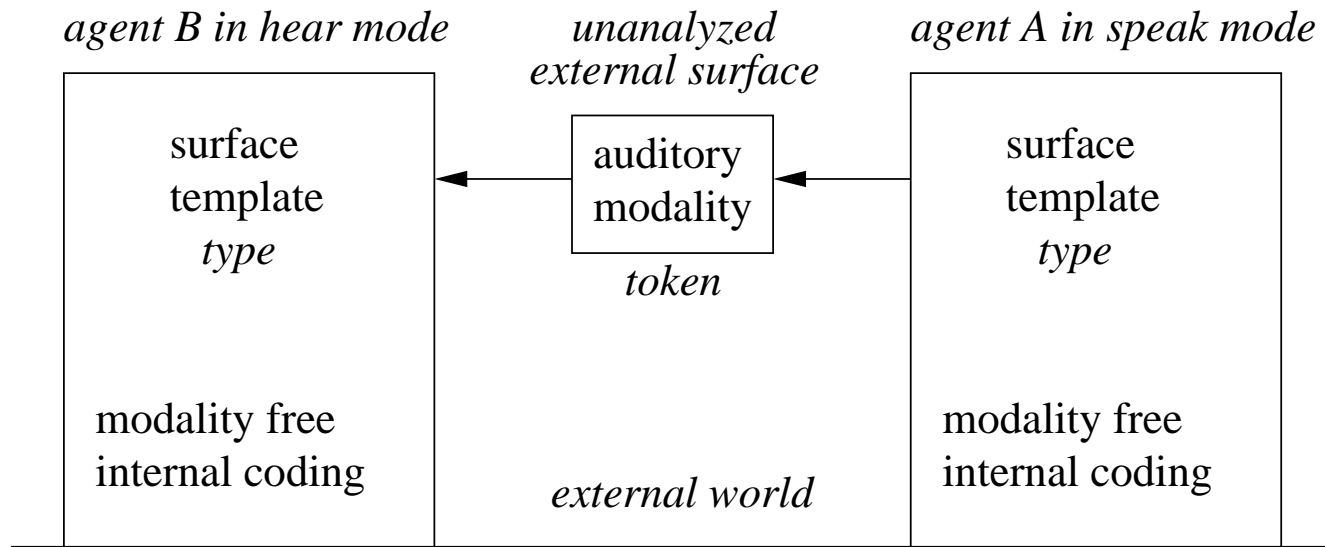

2.3.2 Two kinds of modality conversion

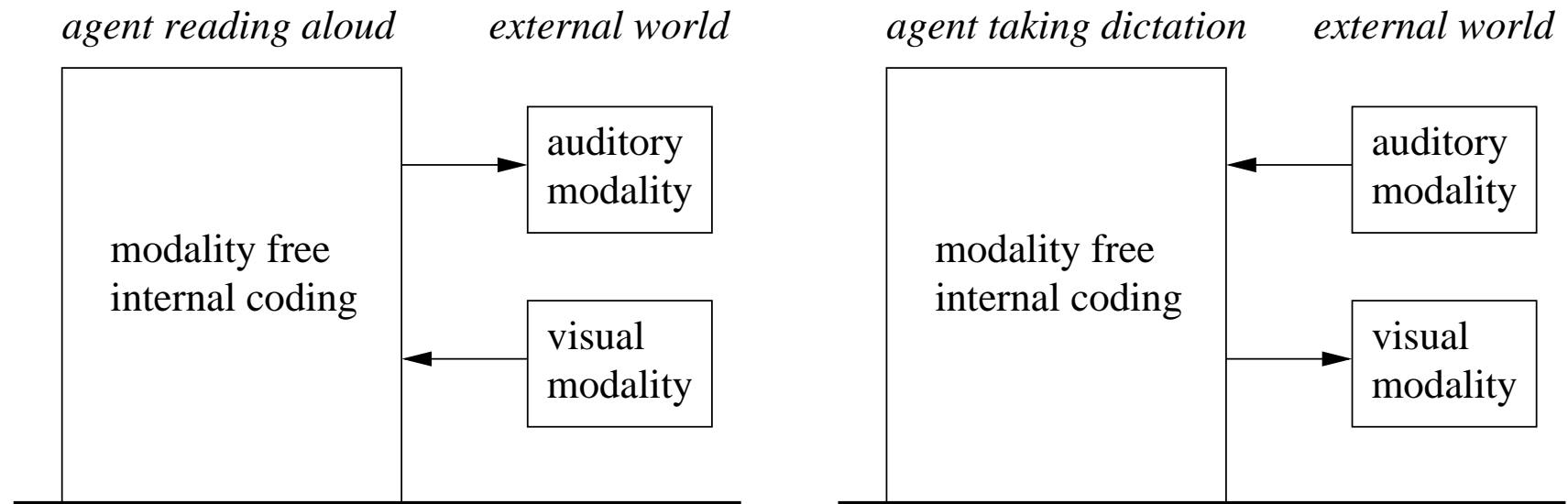

2.5 Backbone of the Communication Cycle

2.5.1 Backbone of surface-based information transfer

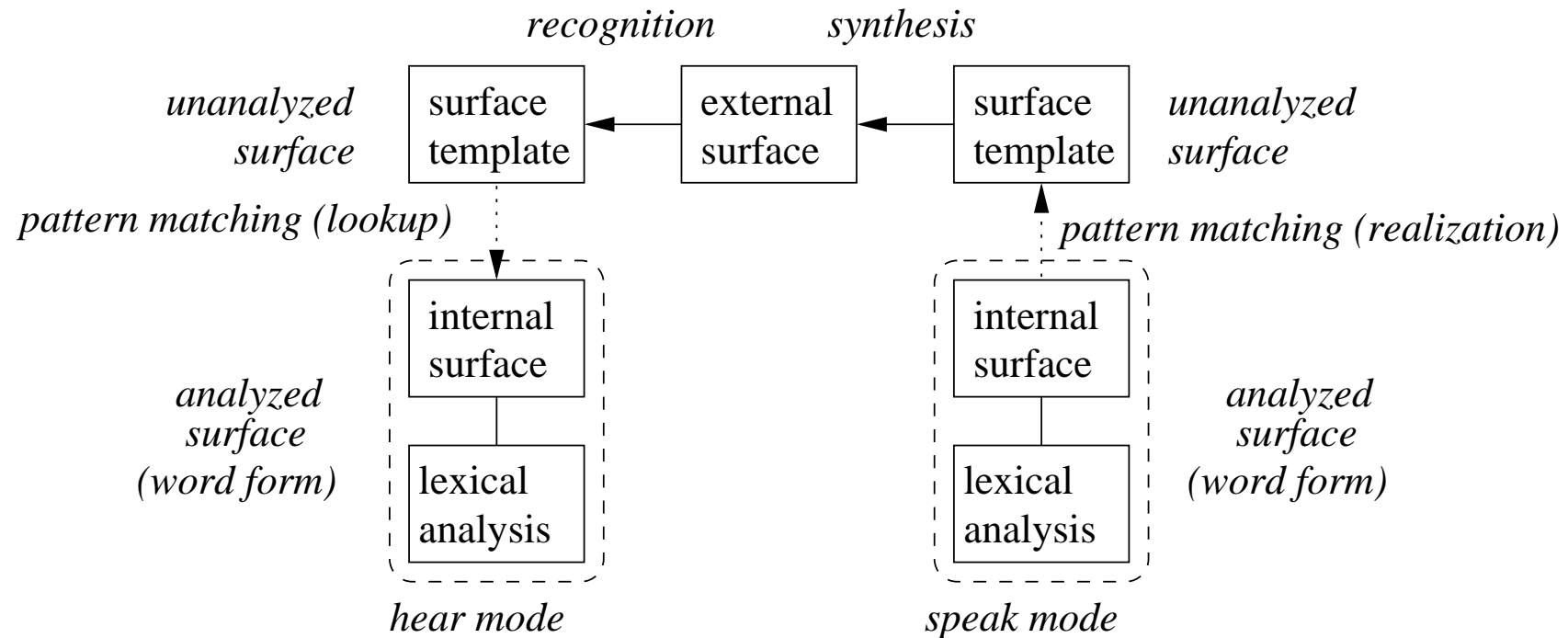

2.5.2 Interface Equivalence Principle

For unrestricted human-machine communication, the artificial cognitive agent with language (DBS robot) must be equipped with the same interfaces to the external environment as the human prototype.

2.5.3 Input/Output Equivalence Principle

In natural language interpretation, the artificial agent must analyze the modality-dependent unanalyzed external surface by

- (i) segmenting it in the same way into parts (i.e., word forms) and
- (ii) ordering the parts in the same way (i.e., in a time-linear sequence)

as the human prototype; and accordingly for language production.

3. Mystery Number Two: Natural Language Communication Cycle

3.1 Choosing the Data Structure

3.1.1 Development of the proplet format

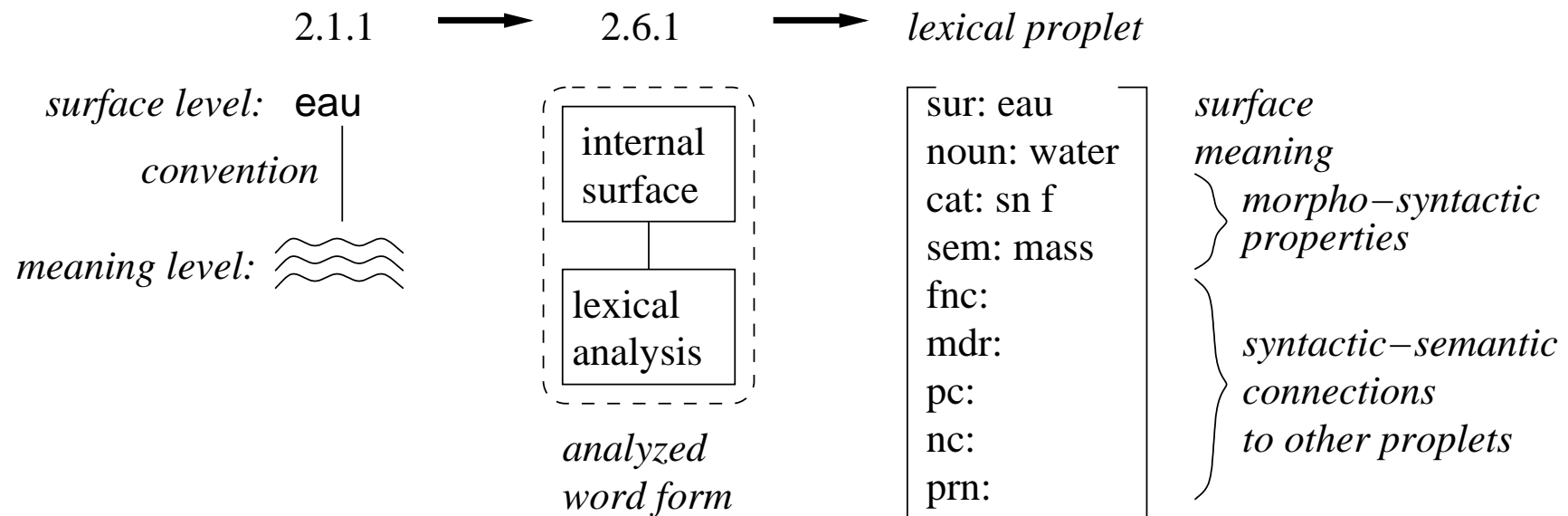

3.2 Representing Content

3.2.1 Functor-argument of Julia knows John.

[noun: Julia fnc: know prn: 625]	[verb: know arg: Julia John prn: 625]	[noun: John fnc: know prn: 625]
---	--	--

3.2.2 Turning 3.2.1 into a schema

[noun: α fnc: β prn: K]	[verb: β arg: $\alpha \gamma$ prn: K]	[noun: γ fnc: β prn: K]
---	--	---

3.2.3 Pattern matching between schema 3.2.2 and content 3.2.1

<i>schema level</i>	[noun: α fnc: β prn: K]	[verb: β arg: $\alpha \gamma$ prn: K]	[noun: γ fnc: β prn: K]
	<i>internal matching</i>		
<i>content level</i>	[noun: Julia fnc: know prn: 625]	[verb: know arg: Julia John prn: 625]	[noun: John fnc: know prn: 625]

3.2.4 Maintaining semantic relations regardless of order

abc

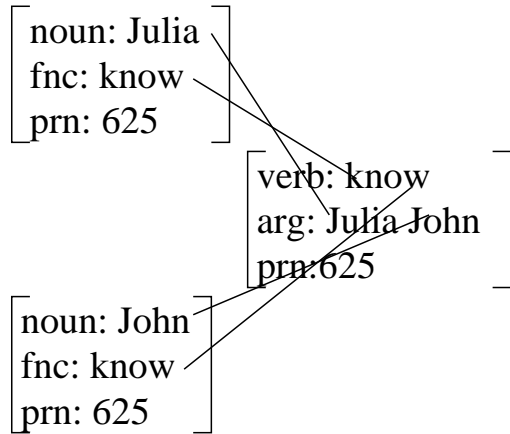

acb

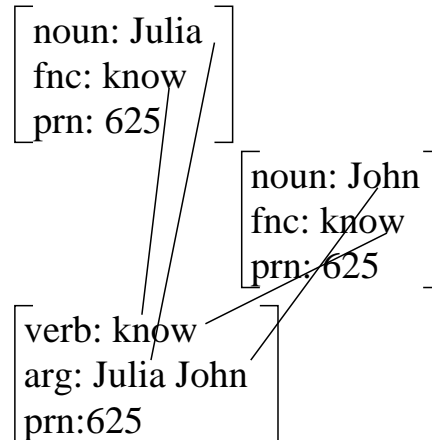

bac

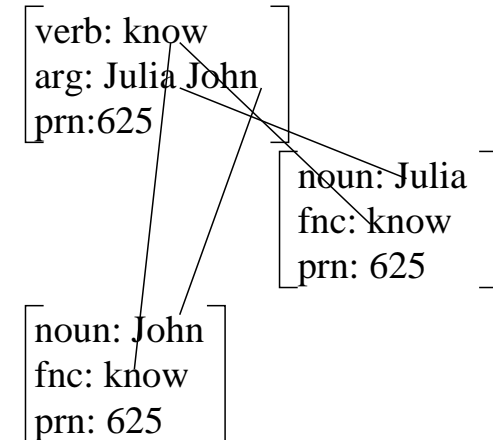

bca

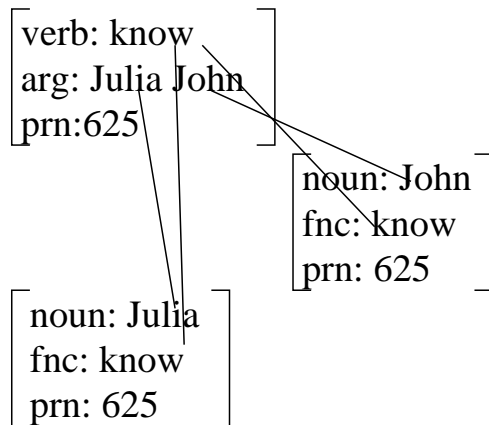

cab

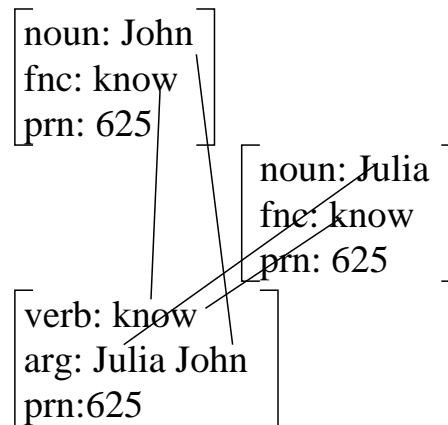

cba

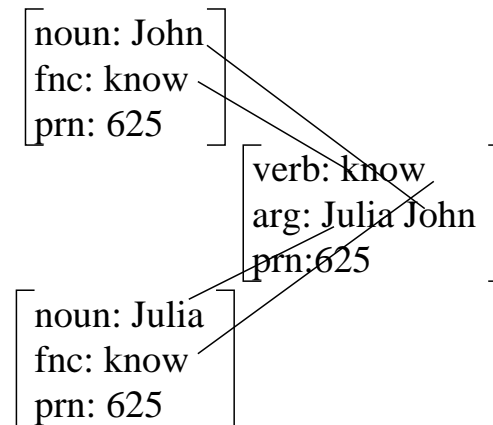

3.2.5 Coordination structure of Julia sang. Sue slept. John read.

[noun: Julia] fnc: sing prn: 10	[verb: sing arg: Julia nc: (sleep 11) pc: prn: 10	[noun: Sue] fnc: sleep prn: 11	[verb: sleep arg: Sue nc: (read 12) pc: (sing 10) prn: 11	[noun: John] fnc: read prn: 12	[verb: read arg: John nc: pc: (sleep 11) prn: 12
---------------------------------------	---	--------------------------------------	---	--------------------------------------	--

3.2.6 Turning 3.2.5 into a schema

[noun: α] fnc: β prn: K	[verb: β arg: α nc: (δ K+1) pc: prn: K	[noun: γ] fnc: δ prn: K+1	[verb: δ arg: γ nc: (ψ K+2) pc: (β K) prn: K+1	[noun: ϕ] fnc: ψ prn: K+2	[verb: ψ arg: ϕ nc: pc: (δ K+1) prn: K+2
---	---	--	---	--	--

3.2.7 Functions based on the order-free nature of proplets

1. Hear mode: storage of proplets in the content-addressable database of a Word Bank.
2. Think mode: selective activation of proplets stored in the Word Bank by means of a navigation along the semantic relations between them, reintroducing a time-linear order.
3. Speak mode: production of natural language as a time-linear sequence of surfaces based on the selective activation of a navigation.
4. Query answering: retrieval of content corresponding to a schema.

3.3 Hear, Think, and Speak Modes

3.3.1 DBS hear mode derivation of Julia knows John.

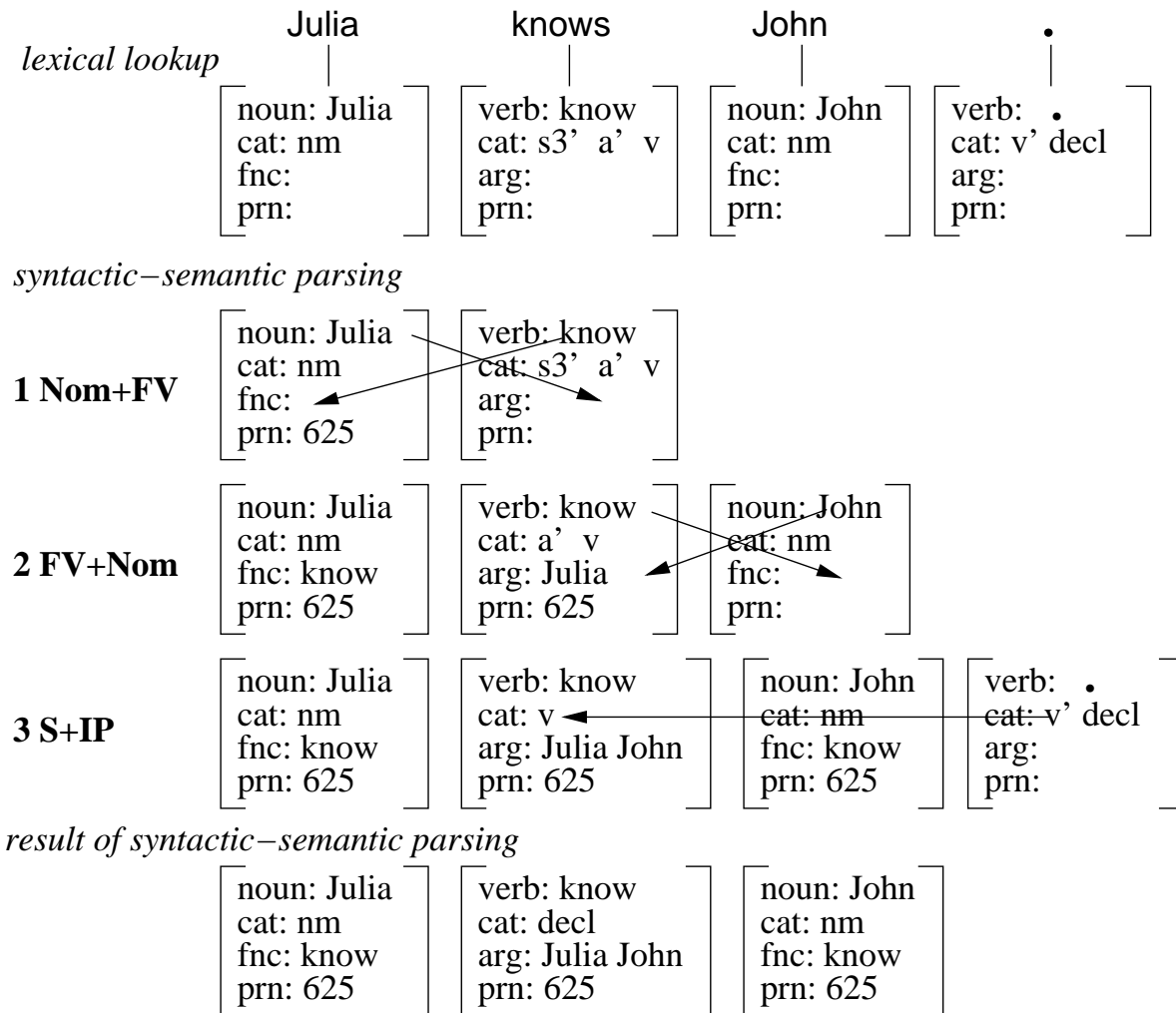

3.3.2 DBS think mode navigation

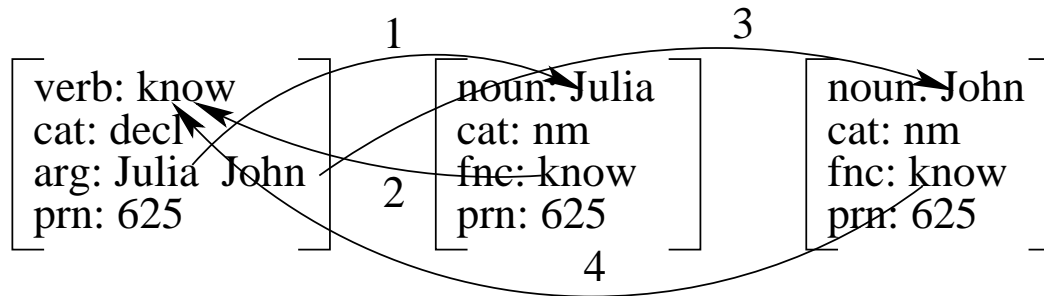

3.3.3 DBS speak mode realization

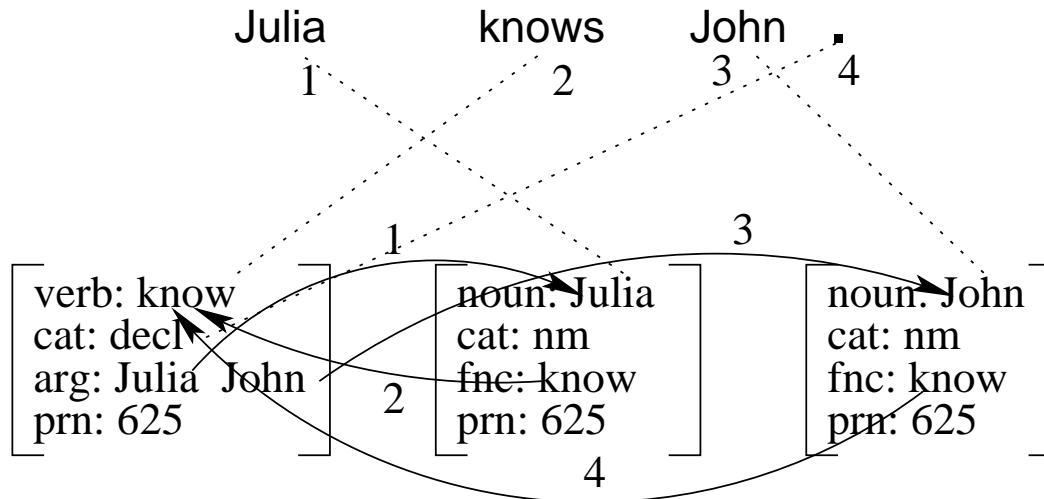

3.4 Algorithm of LA-Grammar

3.4.1 LA-grammar rule application

i. *rule name* ii. *rule package*

Nom+FV {FV+Nom}

iii. *ss-pattern* iv. *nw-pattern* v. *resulting ss'-pattern*

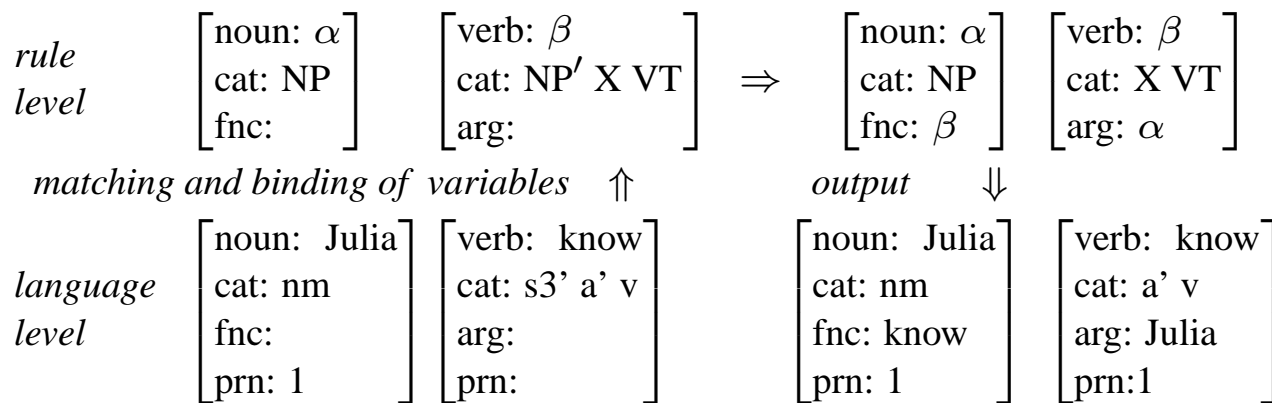

3.4.2 LA-think rule application

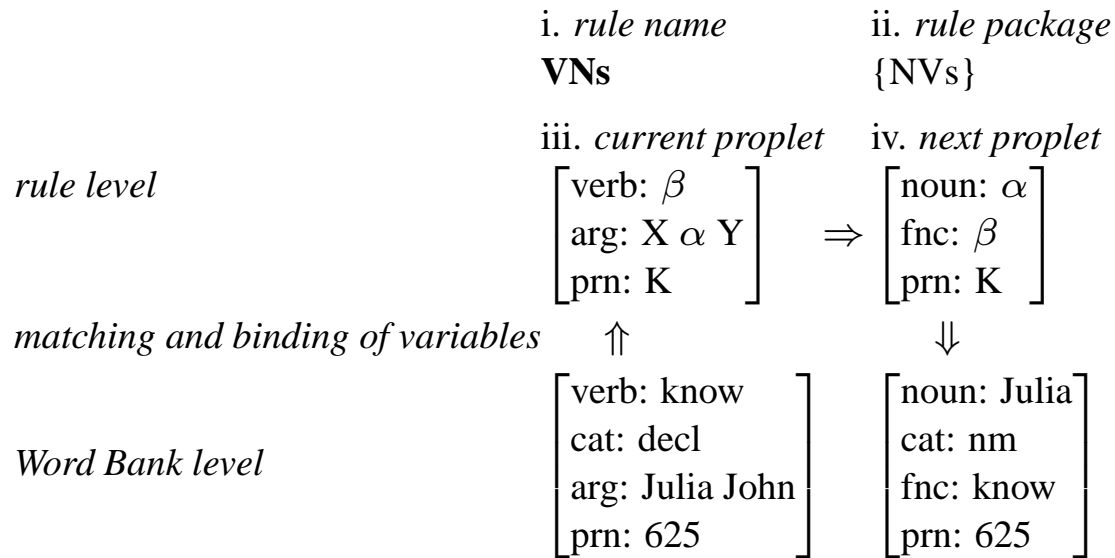

3.4.3 LA-speak rule application

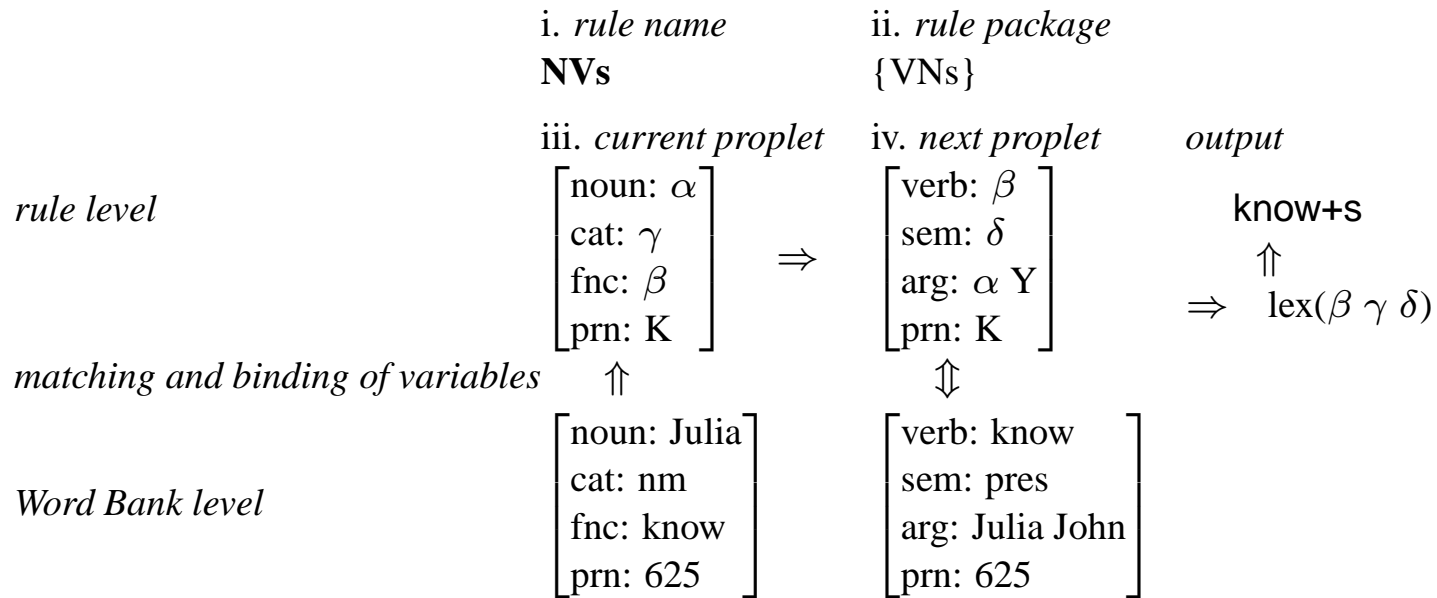

3.4.4 THE SECOND MECHANISM OF COMMUNICATION (MOC-2)

The external time-linear surface order is used for coding grammatical relations proplet-internally (hear mode), while the grammatical relations coded proplet-internally are used for coding a time-linear surface order externally (speak mode).

3.5 Relating Kinds of Proplets to Traditional Parts of Speech

3.5.1 Traditional parts of speech

1. *verb*

Includes finite forms like **sang** and non-finite forms like **singing** or **sung** of main verbs, as well as auxiliaries like **was** or **had** and modals like **could** and **should**. Some traditional grammars treat non-finite verb forms as a separate class called *participle*.

2. *noun*

Includes common nouns like **table** and proper names like **Julia**. Also, count nouns like **book** and mass nouns like **wine** are distinguished.

3. *adjective*

Includes determiners like **a(n)**, **the**, **some**, **all**, and **my** as well as adnominals like **little**, **black**, and **beautiful**. Some traditional grammars treat determiners as a separate class.

4. *adverb*

Includes adverbial modifiers like **beautifully** and intensifiers like **very**.

5. *pronoun*

Includes nouns with an indexical meaning component such as **I**, **me**, **mine**, **you**, **yours**, **he**, **him**, **his**, **she**, **her**, **hers**, etc.

6. *preposition*

Function words which combine with a noun into an adjective, such as **on** in [the book] **on** [the table].

7. *conjunction*

Includes coordinating conjunctions (parataxis) like **and** and subordinating conjunctions (hypotaxis) like **that** (introducing subject or object sentence) or **when** (introducing adverbial sentence).

8. *interjection*

Includes exclamations like **ouch!**, greetings like **hi!**, and answers like **yes**.

3.5.2 Analyzing different kinds of nouns as lexical proplets

common noun

```
[sur: books
noun: book
cat: pn
sem: count pl
fnc:
mdr:
prn:]
```

pronoun

```
[sur: they
noun: ça
cat: pnp
sem: count pl
fnc:
mdr:
prn:]
```

proper name

```
[sur: Julia
noun: Julia
cat: nm
sem: sg
fnc:
mdr:
prn:]
```

determiner

```
[sur: every
noun: n_1
cat: snp
sem: pl exh
fnc:
mdr:
prn:]
```

3.5.3 Analyzing different adjectives as lexical proplets

adnominal

```
[sur: beautiful
adj: beautiful
cat: adn
sem: psv
mdd:
prn:]
```

adverbial

```
[sur: beautifully
adj: beautiful
cat: adv
sem: psv
mdd:
prn:]
```

indexical adjective

```
[sur: here
adj: idx_loc
cat: adv
sem:
mdd:
prn:]
```

preposition

```
[sur: on
adj: on n_2
cat: adv
sem:
mdd:
prn:]
```

3.5.4 Relation between the adnv, adn, and adv values in English

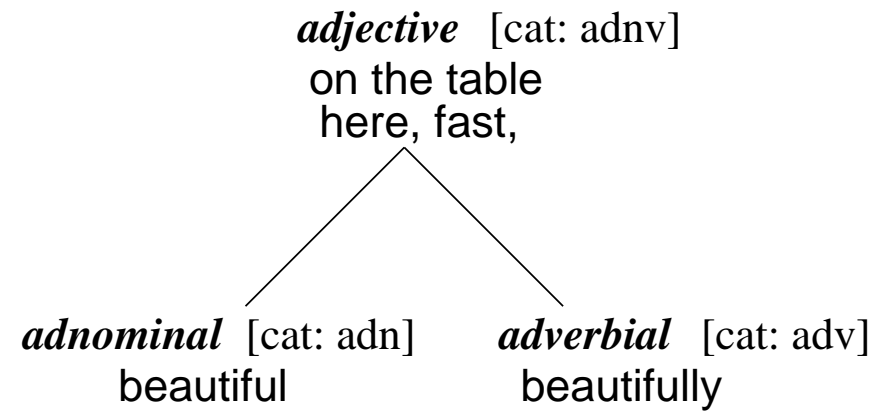

3.5.5 Analyzing different verb forms as lexical proplets

finite main verb

```
[sur: knows
verb: know
cat: ns3' a' v
sem: ind pres
mdr:
arg:
prn:]
```

finite auxiliary

```
[sur: is
verb: v_1
cat: ns3' be' v
sem: ind pres
mdr:
arg:
prn:]
```

non-finite main verb

```
[sur: knowing
verb: know
cat: a' be
sem: prog
mdr:
arg:
prn:]
```

3.5.6 Parts of speech and levels of complexity

	<i>elementary</i>	<i>phrasal</i>	<i>clausal</i>
noun	Julia, she	the beautiful girl	that Fido barked
verb	barked	could have barked	Fido barked.
adj	here, beautiful	in the garden	When Fido barked

3.6 Linguistic Relativism vs. Universal Grammar

3.6.1 Equivalent clauses with different constructions

English: I don't care.

German: Es ist mir egal. (*It is me equal.*)

Italian: Mi lascia indifferente. (*Me leaves-it indifferent.*)

4. Mystery Number Three: Memory Structure

4.1 Database Schema of a Word Bank

4.1.1 Storing the proplets of 3.2.1 in a Word Bank

	<i>member proplets</i>	<i>now front</i>	<i>owner proplets</i>
	
...	$\left[\begin{array}{l} \text{noun: John} \\ \text{cat: nm} \\ \text{fnc: ...} \\ \text{prn: 610} \end{array} \right]$	$\left[\begin{array}{l} \text{noun: John} \\ \text{cat: nm} \\ \text{fnc: know} \\ \text{prn: 625} \end{array} \right]$	[core: John]
	
...	$\left[\begin{array}{l} \text{noun: Julia} \\ \text{cat: nm} \\ \text{fnc: ...} \\ \text{prn: 605} \end{array} \right]$	$\left[\begin{array}{l} \text{noun: Julia} \\ \text{cat: nm} \\ \text{fnc: know} \\ \text{prn: 625} \end{array} \right]$	[core: Julia]
	
...	$\left[\begin{array}{l} \text{verb: know} \\ \text{cat: decl} \\ \text{arg: ...} \\ \text{prn: 608} \end{array} \right]$	$\left[\begin{array}{l} \text{verb: know} \\ \text{cat: decl} \\ \text{arg: Julia John} \\ \text{prn: 625} \end{array} \right]$	[core: know]
	

4.2 Retrieving Answers to Questions

4.2.1 Example of a token line

		<i>member proplets</i>	<i>now front</i>	<i>owner proplet</i>
$\left[\begin{array}{l} \text{noun: girl} \\ \text{fnc: walk} \\ \text{mdr: young} \\ \text{prn: 10} \end{array} \right]$	$\left[\begin{array}{l} \text{noun: girl} \\ \text{fnc: sleep} \\ \text{mdr: blond} \\ \text{prn: 12} \end{array} \right]$	$\left[\begin{array}{l} \text{noun: girl} \\ \text{fnc: eat} \\ \text{mdr: small} \\ \text{prn: 15} \end{array} \right]$	$\left[\begin{array}{l} \text{noun: girl} \\ \text{fnc: read} \\ \text{mdr: smart} \\ \text{prn: 19} \end{array} \right]$	$\left[\text{core: } \textit{girl} \right]$

4.2.2 Applying a query pattern

	<i>query pattern</i>	$\left[\begin{array}{l} \text{noun: } \textit{girl} \\ \text{fnc: walk} \\ \text{mdr: } \sigma \\ \text{prn: K} \end{array} \right]$		
		<i>matching (?)</i>		
$\left[\begin{array}{l} \text{noun: girl} \\ \text{fnc: walk} \\ \text{mdr: young} \\ \text{prn: 10} \end{array} \right]$	$\left[\begin{array}{l} \text{noun: girl} \\ \text{fnc: sleep} \\ \text{mdr: blonde} \\ \text{prn: 12} \end{array} \right]$	$\left[\begin{array}{l} \text{noun: girl} \\ \text{fnc: eat} \\ \text{mdr: small} \\ \text{prn: 15} \end{array} \right]$	$\left[\begin{array}{l} \text{noun: girl} \\ \text{fnc: read} \\ \text{mdr: smart} \\ \text{prn: 19} \end{array} \right]$	$\left[\text{core: } \textit{girl} \right]$

4.3 Reference as a Purely Cognitive Procedure

4.3.1 Model-theoretic reconstruction of reference

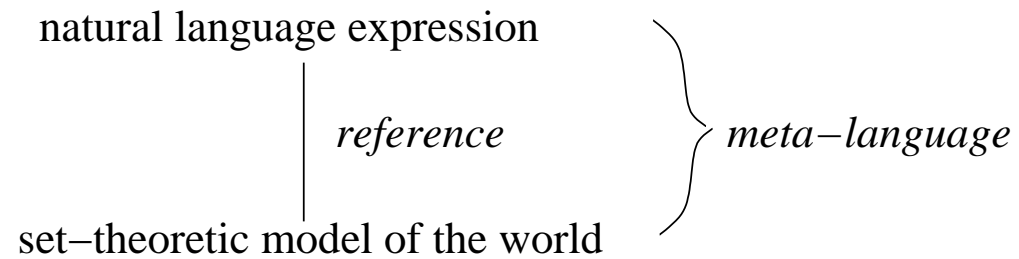

4.3.2 Interfaces and components of an agent with language

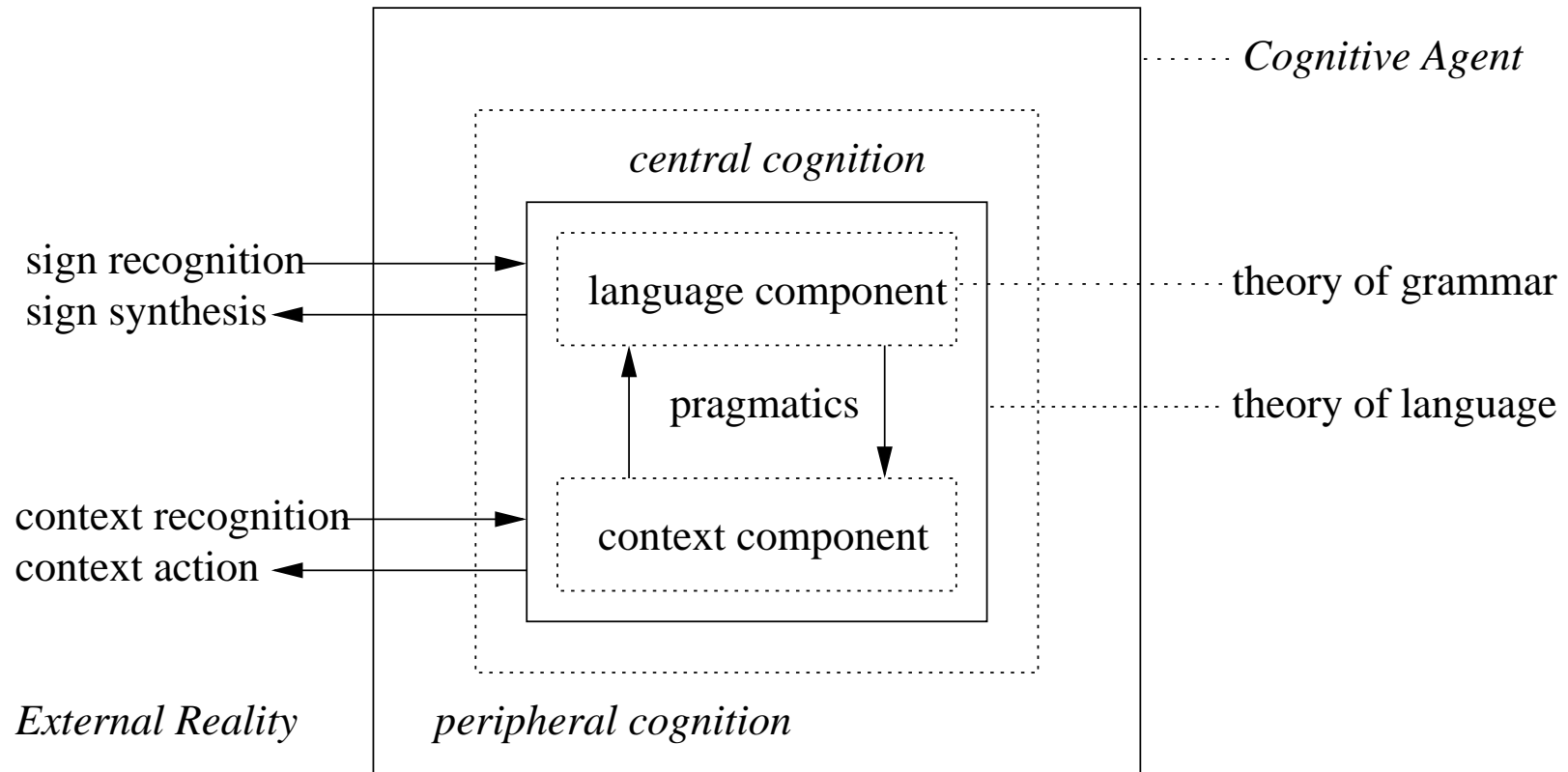

4.3.3 Reference as language-context pattern matching

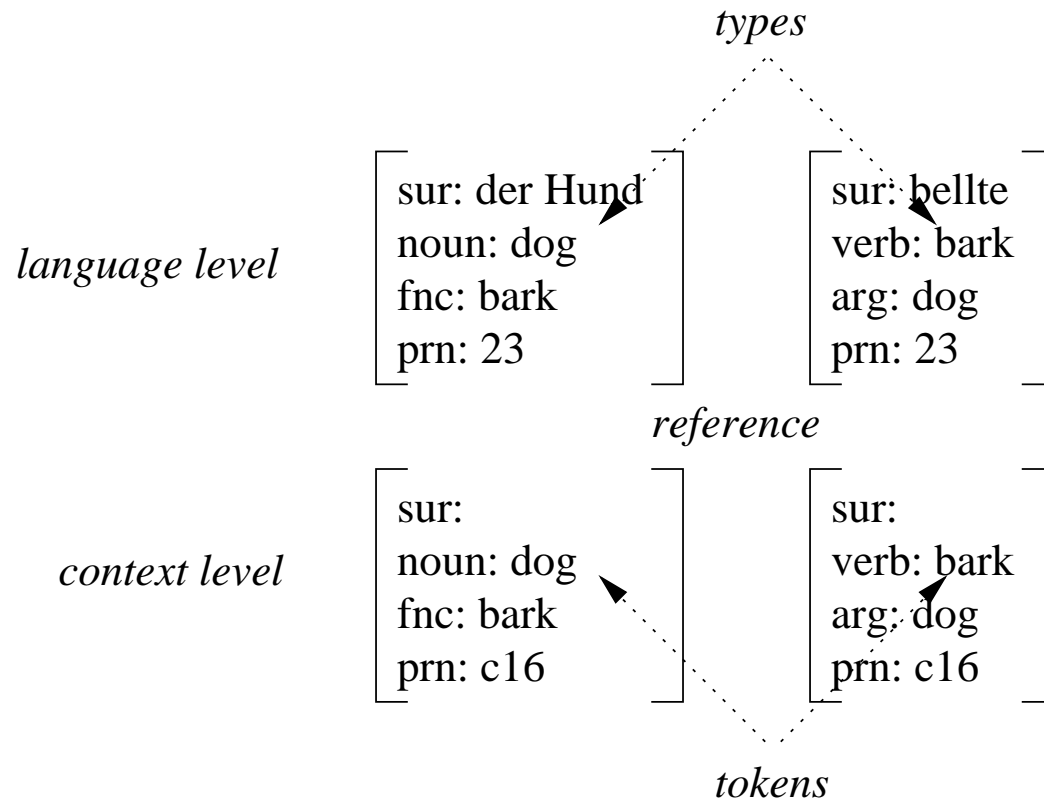

4.4 Coreference-by-Address

4.4.1 Symbolic addresses resulting from copying

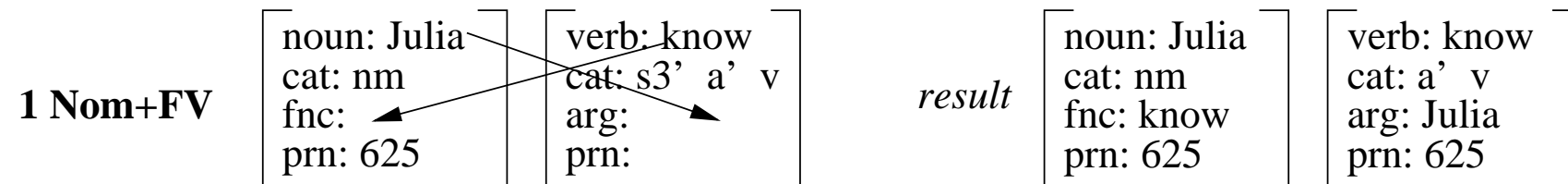

4.4.2 Coreferential coordination in a Word Bank

... $\left[\begin{array}{l} \text{noun: Julia} \\ \text{fnc: sleep} \\ \text{prn: 675} \end{array} \right]$... $\left[\begin{array}{l} \text{noun: (Julia 675)} \\ \text{fnc: wake} \\ \text{prn: 702} \end{array} \right]$... [core: Julia]
 ...
 $\left[\begin{array}{l} \text{verb: wake} \\ \text{arg: (Julia 675)} \\ \text{prn: 702} \end{array} \right]$... [core: wake]
 ...
 ... $\left[\begin{array}{l} \text{verb: sleep} \\ \text{arg: Julia} \\ \text{prn: 675} \end{array} \right]$... [core: sleep]

4.4.3 Coreferential navigation

$\left[\begin{array}{l} \text{verb: sleep} \\ \text{arg: Julia} \\ \text{prn: 675} \end{array} \right] \overset{1}{\leftrightarrow} \left[\begin{array}{l} \text{noun: Julia} \\ \text{fnc: sleep} \\ \text{prn: 675} \end{array} \right] \overset{2}{\leftrightarrow} \left[\begin{array}{l} \text{noun: (Julia 675)} \\ \text{fnc: wake} \\ \text{prn: 702} \end{array} \right] \overset{3}{\leftrightarrow} \left[\begin{array}{l} \text{verb: wake} \\ \text{arg: (Julia 675)} \\ \text{prn: 702} \end{array} \right]$

4.5 Component Structure and Functional Flow

4.5.1 Pattern matching based on the type-token relation

a. *Recognition:*

matching between concept types and raw input

b. *Action:*

matching between concept tokens and concept types

c. *Reference:*

matching between language and context proplets

4.5.2 Pattern matching based on restricted variables

- a. *Natural Language Interpretation:*
matching between LA-hear rules and language proplets (3.4.1)
- b. *Navigation:*
matching between LA-think rules and content proplets (3.4.2)
- c. *Production from Stored Content:*
matching between LA-speak rules and content proplets (3.4.3)
- d. *Querying:*
matching between query patterns and content proplets (4.2.2)
- e. *Inferencing:*
matching between inference rules and content proplets (5.2.3 and 5.3.4)

4.5.3 Refined component structure of a cognitive agent

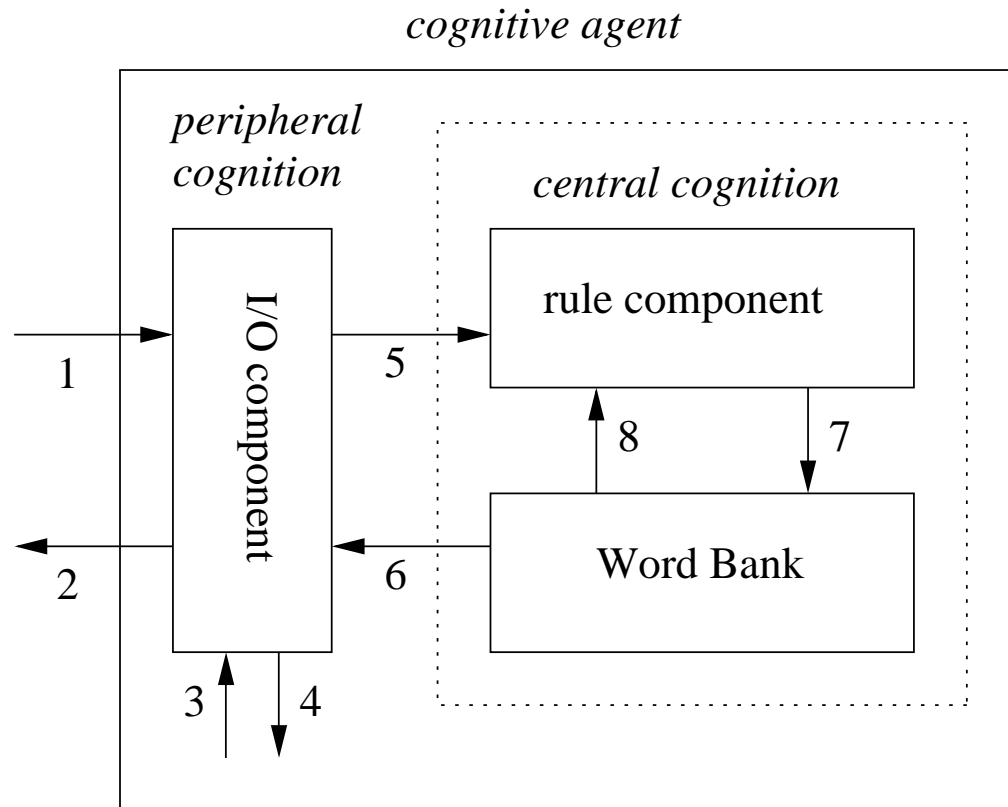

- 1 = external recognition
- 2 = external action
- 3 = internal recognition
- 4 = internal action
- 5 = input to rule component
- 6 = output of Word Bank
- 7 = rule-Word_Bank interaction
- 8 = Word_Bank-rule interaction

4.5.4 Integrating diagram 4.3.2 into diagram 4.5.3

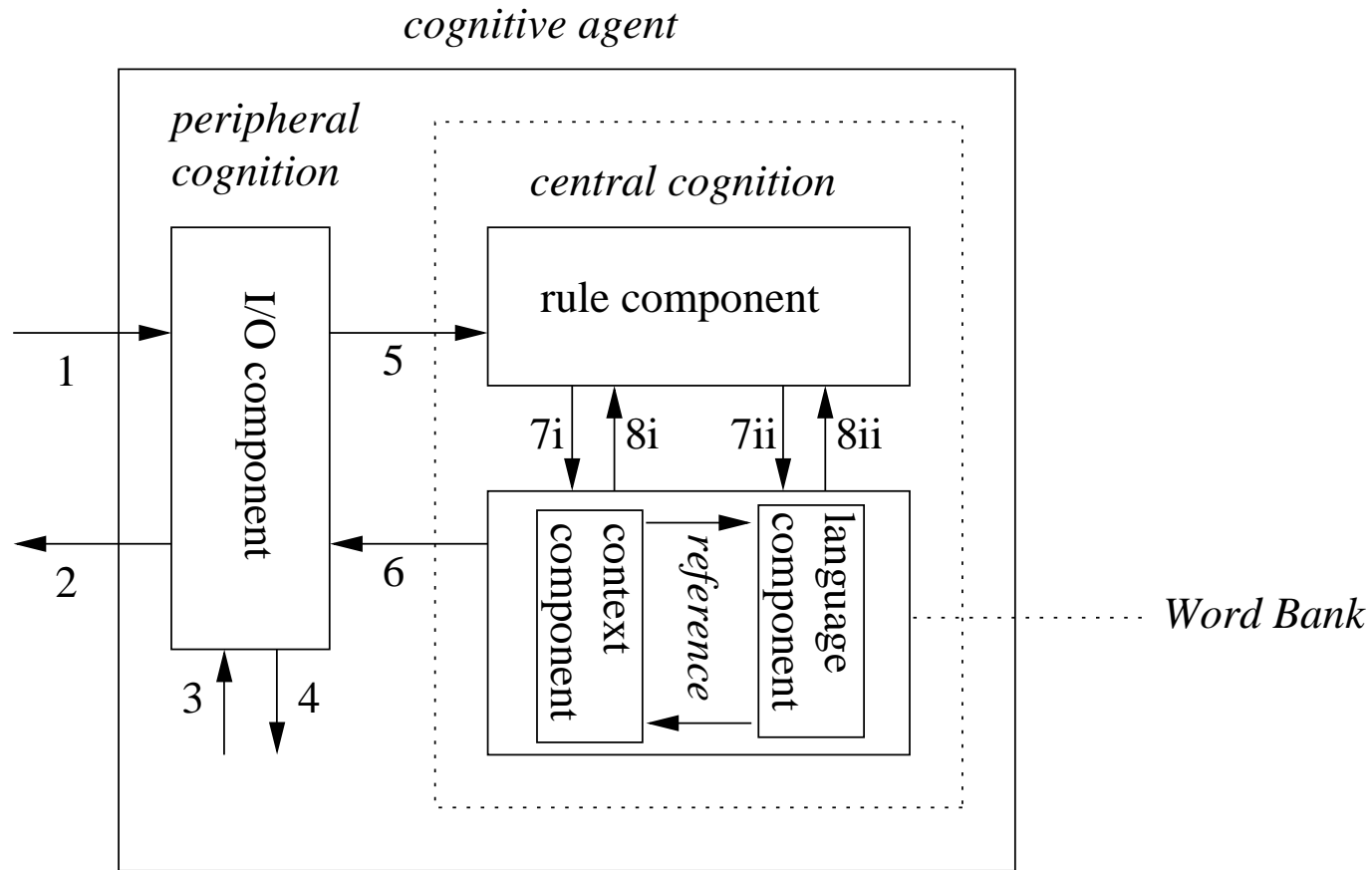

4.5.5 The Third Mechanism of Communication (MoC-3)

The operations of cognition in general and of natural language communication in particular require a memory with a storage and retrieval mechanism supporting (i) extensive data coverage, (ii) functional completeness, and (iii) efficiency which enables real-time performance.

4.6 Embedding the Cycle of Communication into the Agent

4.6.1 Mapping incoming surfaces into content (hear mode)

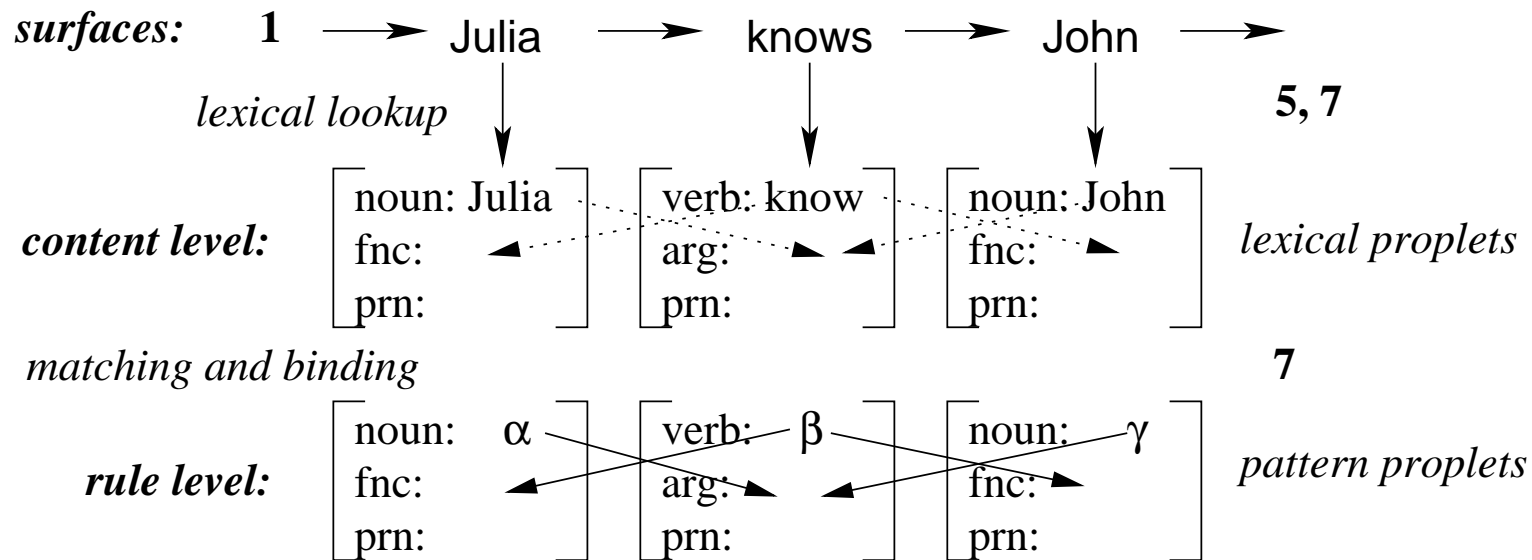

4.6.2 Mapping stored content into surfaces (speak mode)

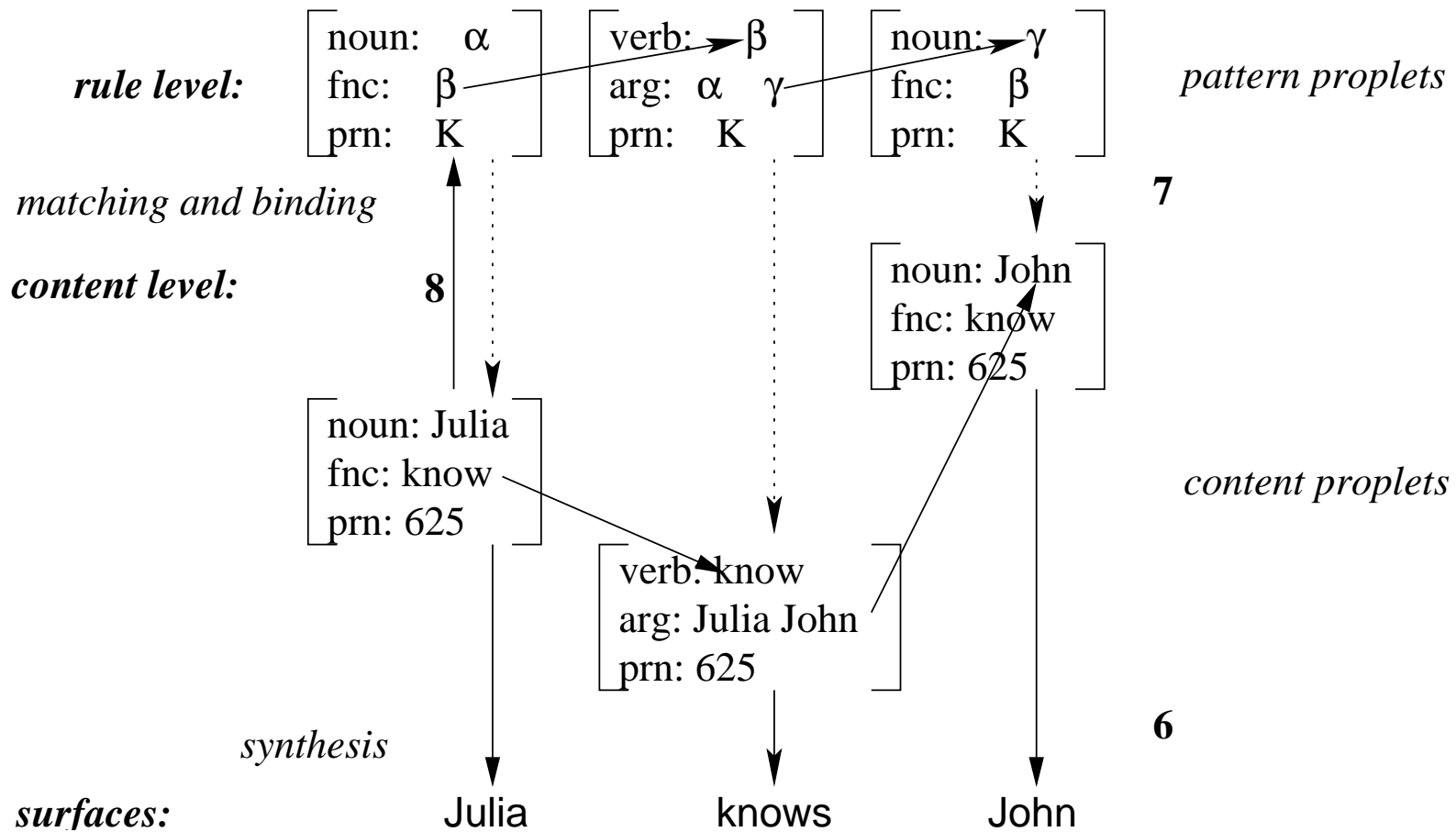

4.6.3 Inference producing outgoing surfaces

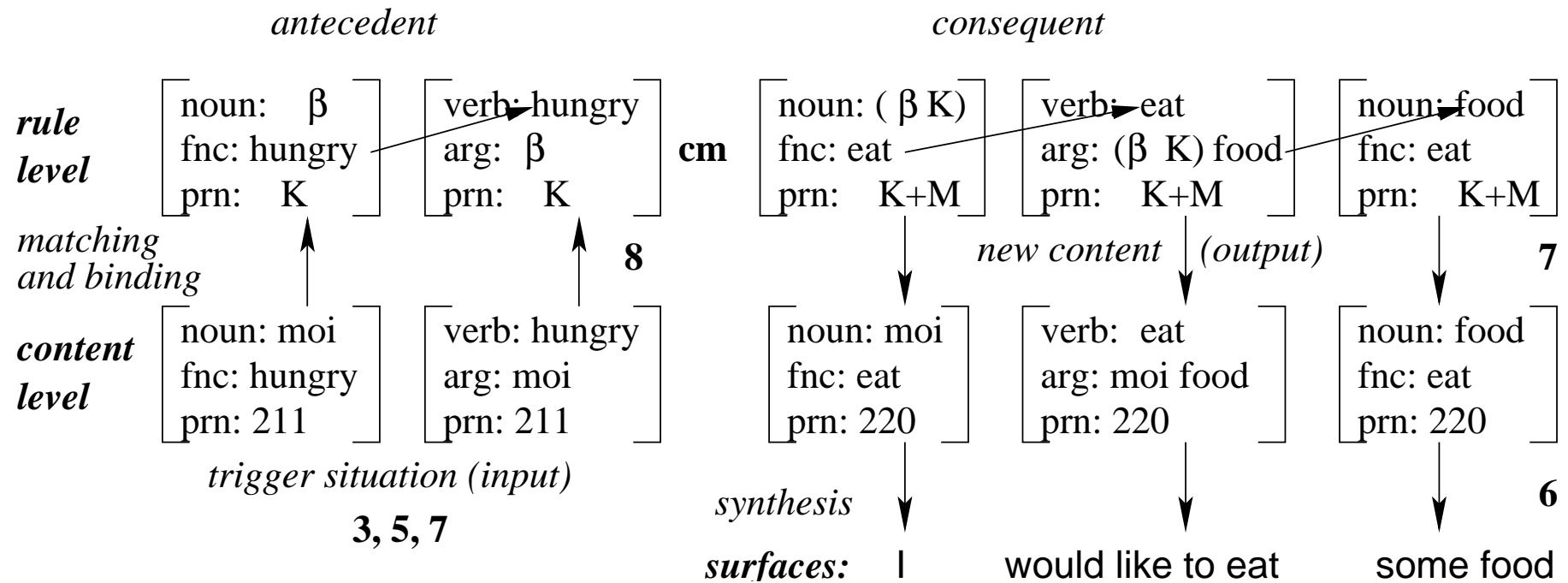

5. Mystery Number Four: **Autonomous Control**

5.1 Pinball Machine Model of Cognition

5.1.1 Definition of meaning by Grice

Definiendum: U meant something by uttering x.

Definiens: For some audience A, U intends his utterance of x to produce in A some effect (response) E, by means of A's recognition of the intention.

5.1.2 The Fourth Mechanism of Communication (MoC-4)

The language as well as the nonlanguage behavior of a cognitive agent is driven by the goal of autonomous control to maintain a continuous state of balance vis à vis constantly changing external and internal environments. The success of autonomous control, short-, mid-, and long-term, is defined in terms of survival in the agent's ecological niche.

5.2 DBS Inferences for Maintaining Balance

5.2.1 Chaining R, D, and E inferences

- | | | | | | |
|---|-----|-------------|-------------------------------------|-----|---|
| 1. R: β be hungry | K | cm | β eat food | K+1 | |
| 2. D: β eat food | K+1 | pre | β get food | K+2 | |
| 3. D: β get food | K+2 | down | β get α , | K+3 | where $\alpha \in \{\text{apple, pear, salad, steak}\}$ |
| 4. E: β get α | K+3 | exec | β locate α at γ | K+4 | |
| 5. E: β locate α at γ | K+4 | exec | β take α | K+5 | |
| 6. E: β take α | K+5 | exec | β eat α | K+6 | |
| 7. D: β eat α | K+6 | up | β eat food | K+7 | |

5.2.2 One-step chain based on an R/E inference

R/E: α feel full K **cm/exec** α stop eating K+1

5.2.3 Formal definition and application of a DBS inference

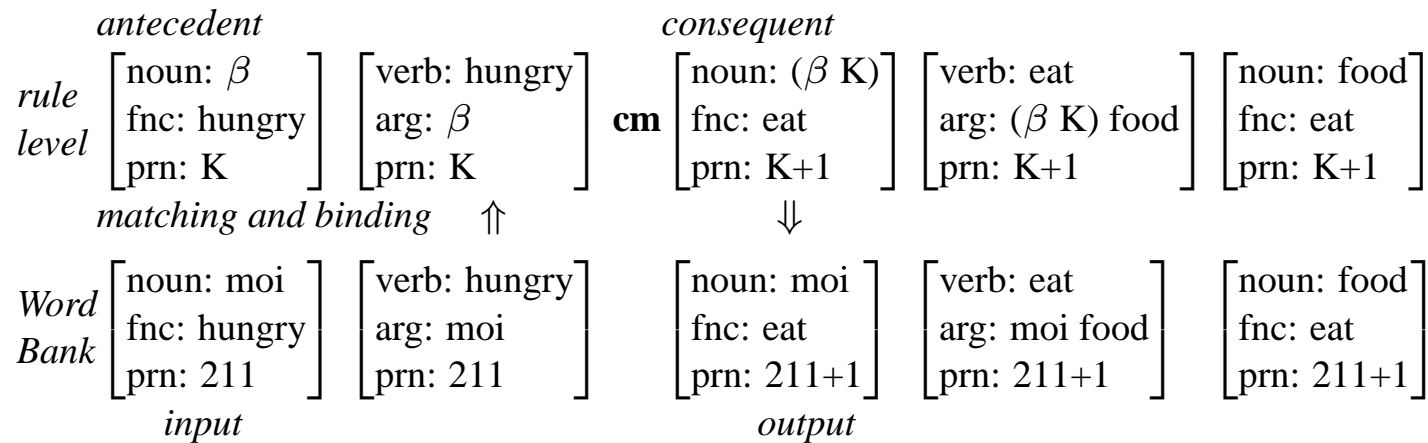

5.2.4 Sequential Inferencing Principle (SIP)

Any two inferences x and y may be applied in sequence if, and only if, the consequent of x equals the antecedent of y.

5.2.5 New content derived by the inference chain 5.2.1

rule level: β be hungry K **cm** β eat food K+1 **pre**

Word Bank: moi be hungry 211 moi eat food 212

β get (food K+1) K+2 **down** β get α K+3 **exec**

moi get (food 212) 213 moi get apple 214

β locate α at γ K+4 **exec** β take α K+5 **exec**

moi locate (apple 214) at cupboard 215 moi take (apple 214) 216

β (eat K+1) α K+6 **up** β (eat K+1) (food K+1) K+7

moi (eat 212) (apple 214) 217 moi (eat 212) (food 212) 218

The four double lines should be read as one, i.e., as

rule level: p1 **cm** p2 **pre** p3 **down** p4 **exec** p5 **exec** p6 **exec** p7 **up** p8

Word Bank: q1 q2 q3 q4 q5 q6 q7 q8.

5.3 DBS Inferences for Meaning and Event Relations

5.3.1 Inference rule implementing a synonymy

$$\left[\begin{array}{l} \text{noun: abstract} \\ \text{fnc: } \alpha \\ \text{prn: K} \end{array} \right] \text{impl} \left[\begin{array}{l} \text{noun: summary} \\ \text{fnc: } \alpha \\ \text{prn: K+M} \end{array} \right] \text{ where } \alpha \in \{\text{write, read, discuss, ...}\}$$

5.3.2 Inference rule implementing an antonymy

$$\left[\begin{array}{l} \text{adj: good} \\ \text{mdd: } \alpha \\ \text{prn: K} \end{array} \right] \text{impl} \left[\begin{array}{l} \text{adj: not bad} \\ \text{mdd: } \alpha \\ \text{prn: K+M} \end{array} \right]$$

5.3.3 Inference rule implementing a cause and effect relation

If a car has no fuel then it does not start

$$\left[\begin{array}{l} \text{noun: car} \\ \text{fnc: have} \\ \text{prn: K} \end{array} \right] \left[\begin{array}{l} \text{verb: have} \\ \text{arg: car no fuel} \\ \text{prn: K} \end{array} \right] \left[\begin{array}{l} \text{noun: no fuel} \\ \text{fnc: have} \\ \text{prn: K} \end{array} \right] \text{impl} \left[\begin{array}{l} \text{noun: (car K)} \\ \text{fnc: no start} \\ \text{prn: K+M} \end{array} \right] \left[\begin{array}{l} \text{verb: no start} \\ \text{arg: (car K)} \\ \text{prn: K+M} \end{array} \right]$$

5.3.4 Relating summary car accident to text

The heavy old car hit a beautiful tree. The car had been speeding. A farmer gave the driver a lift.

		<i>member proplets</i>	<i>owner proplets</i>
...		[noun: accident mdr: (car 1) prn: 67]	... [core: accident]
...			
...	[noun: car fnc: hit prn: 1]	[noun: (car 1) fnc: speed prn: 2]	...
...		[noun: (car 1) mdd: accident prn: 67]	... [core: car]
...			
...	[verb: hit arg: car tree prn: 1] [core: hit]
...		[verb: speed arg: (car 1) prn: 2]	... [core: speed]
...			

5.3.5 Summary-creating D inference

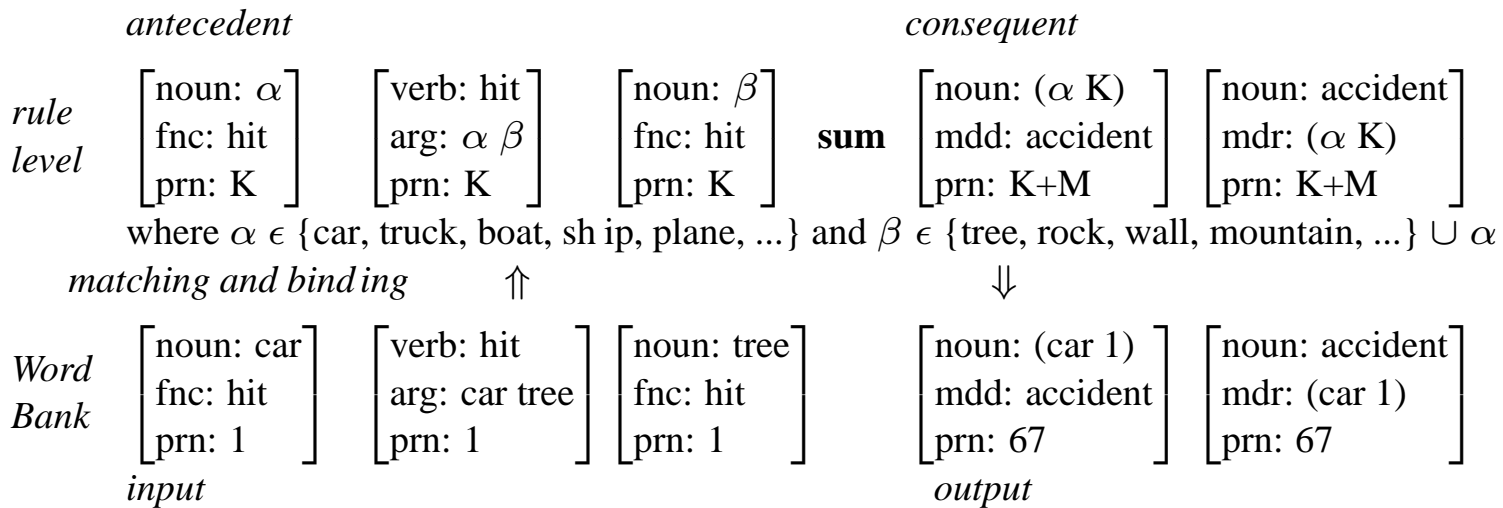

5.4.2 Intersecting token lines for *hot* and *potato*

			<i>member proplets</i>	<i>owner proplets</i>	
...	$\left[\begin{array}{l} \text{adj: hot} \\ \text{mdd: potato} \\ \text{prn: 20} \end{array} \right]$	$\left[\begin{array}{l} \text{adj: hot} \\ \text{mdd: water} \\ \text{prn: 32} \end{array} \right]$	$\left[\begin{array}{l} \text{adj: hot} \\ \text{mdd: potato} \\ \text{prn: 55} \end{array} \right]$	$\left[\begin{array}{l} \text{adj: hot} \\ \text{mdd: day} \\ \text{prn: 79} \end{array} \right]$	$\left[\text{core: hot} \right]$
...	$\left[\begin{array}{l} \text{noun: potato} \\ \text{fnc: look_for} \\ \text{mdr: hot} \\ \text{prn: 20} \end{array} \right]$	$\left[\begin{array}{l} \text{noun: potato} \\ \text{fnc: cook} \\ \text{mdr: big} \\ \text{prn: 35} \end{array} \right]$	$\left[\begin{array}{l} \text{noun: potato} \\ \text{fnc: find} \\ \text{mdr: hot} \\ \text{prn: 55} \end{array} \right]$	$\left[\begin{array}{l} \text{noun: potato} \\ \text{fnc: eat} \\ \text{mdd: small} \\ \text{prn: 88} \end{array} \right]$	$\left[\text{core: potato} \right]$

5.4.3 Completing an intersection by spreading activation

$\left[\begin{array}{l} \text{noun: John} \\ \text{fnc: look_for} \\ \text{prn: 20} \end{array} \right]$	$\left[\begin{array}{l} \text{verb: look_for} \\ \text{arg: John, potato} \\ \text{pc: cook 19} \\ \text{nc: eat 21} \\ \text{prn: 20} \end{array} \right]$	$\left[\begin{array}{l} \text{noun: potato} \\ \text{fnc: look_for} \\ \text{mdr: hot} \\ \text{prn: 20} \end{array} \right]$	$\left[\begin{array}{l} \text{adj: hot} \\ \text{mdd: potato} \\ \text{prn: 20} \end{array} \right]$
--	---	---	---

5.5 Analogical Models for Problem Solving

5.5.1 Two *Mary eat* intersections

$\left[\begin{array}{l} \text{noun: (Mary 25)} \\ \text{fnc: eat} \\ \text{prn: 48} \end{array} \right]$	$\left[\begin{array}{l} \text{verb: eat} \\ \text{arg: (Mary 25) (apple 46)} \\ \text{pc: take 47} \\ \text{prn: 48} \end{array} \right]$	$\left[\begin{array}{l} \text{noun: (Mary 25)} \\ \text{fnc: eat} \\ \text{prn: 82} \end{array} \right]$	$\left[\begin{array}{l} \text{verb: eat} \\ \text{arg: (Mary 25) (müsli 80)} \\ \text{pc: prepare 81} \\ \text{prn: 82} \end{array} \right]$
---	--	---	---

5.5.2 Subactivation spreading from *Mary eat* to *Mary eat apple*

$\left[\begin{array}{l} \text{noun: (Mary 25)} \\ \text{fnc: eat} \\ \text{prn: 48} \end{array} \right]$	$\left[\begin{array}{l} \text{verb: eat} \\ \text{arg: (Mary 25) (apple 46)} \\ \text{pc: take 47} \\ \text{prn: 48} \end{array} \right]$	$\left[\begin{array}{l} \text{noun: (apple 46)} \\ \text{fnc: eat} \\ \text{eval: attract} \\ \text{prn: 48} \end{array} \right]$
---	--	--

5.5.3 Stored content matching consequent in inference chain

rule level: β be hungry K **cm** β eat food K+1 **pre**
 Word Bank # #

β get food K+2 **down** β get α K+3 **exec**
 # #

β locate α at γ K+4 **exec** β take α K+5 **exec**
 # #

β eat α K+6 **up** β eat food K+7
 (Mary 25) eat (apple 46) 48 #

5.5.4 Extending matching content by secondary subactivation

rule level: β be hungry K **cm** β eat food K+1 **pre**

Word Bank: # #

β get food K+2 **down** β get α K+3 **exec**
#

β locate α at γ K+4 **exec**
(Mary 25) locate apple at cupboard 46

β take α K+5 **exec**
(Mary 25) take (apple 46) 47

β eat α K+6 **up** β eat food K+7
(Mary 25) eat (apple 46) 48 #

5.5.5 Transfer and completion

rule level: β be hungry K **cm** β eat food K+1 **pre**

Word Bank: # #

β get food K+2 **down** β get α K+3 **exec**
#

β locate α at γ K+4 **exec**
moi locate apple at cupboard 91

β take α K+5 **exec**
moi take (apple 91) 92

β eat α K+6 **up** β eat food K+7
moi eat (apple 91) 93 moi eat food 94

5.6 Subjunctive Transfer and Managing the Data Stream

5.6.1 Inference changing subjunctive to imperative content

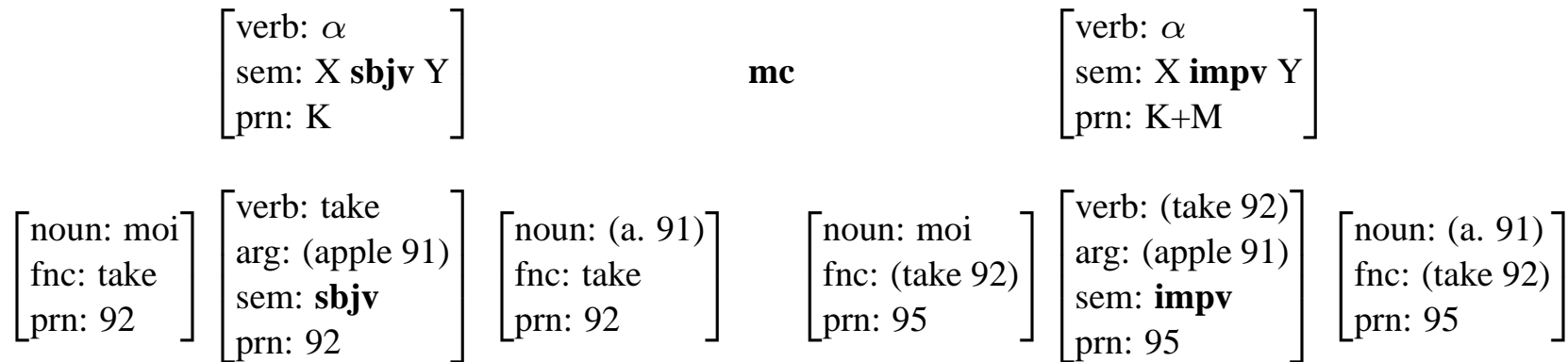

6. Mystery Number Five: Learning

6.1 Fixed Behavior Agents

6.1.1 Motion patterns of a fixed behavior agent

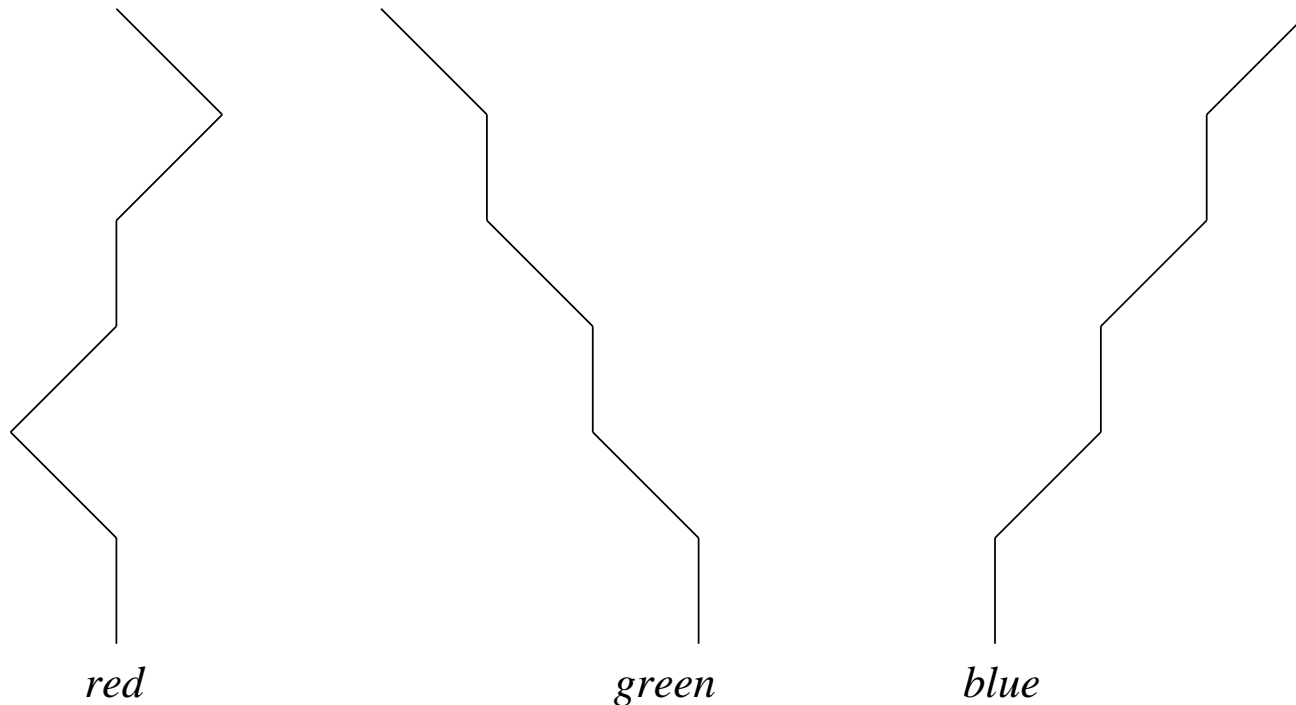

6.1.2 Coding motion triggered by red as set of proplets

$\left[\begin{array}{l} \text{rec: red} \\ \text{prev:} \\ \text{next: strght} \\ \text{prn: } x_1 \end{array} \right]$	$\left[\begin{array}{l} \text{act: strght} \\ \text{prev: red} \\ \text{next: left} \\ \text{prn: } x_2 \end{array} \right]$	$\left[\begin{array}{l} \text{act: left} \\ \text{prev: strght} \\ \text{next: right} \\ \text{prn: } x_3 \end{array} \right]$	$\left[\begin{array}{l} \text{act: right} \\ \text{prev: left} \\ \text{next: strght} \\ \text{prn: } x_4 \end{array} \right]$	$\left[\begin{array}{l} \text{act: strght} \\ \text{prev: right} \\ \text{next: right} \\ \text{prn: } x_5 \end{array} \right]$	$\left[\begin{array}{l} \text{act: right} \\ \text{prev: strght} \\ \text{next: left} \\ \text{prn: } x_6 \end{array} \right]$	$\left[\begin{array}{l} \text{act: left} \\ \text{prev: right} \\ \text{next:} \\ \text{prn: } x_7 \end{array} \right]$
--	---	---	---	--	---	--

6.1.3 Coding motion triggered by green as set of proplets

$\left[\begin{array}{l} \text{rec: green} \\ \text{prev:} \\ \text{next: strght} \\ \text{prn: } y_1 \end{array} \right]$	$\left[\begin{array}{l} \text{act: strght} \\ \text{prev: green} \\ \text{next: left} \\ \text{prn: } y_2 \end{array} \right]$	$\left[\begin{array}{l} \text{act: left} \\ \text{prev: strght} \\ \text{next: strght} \\ \text{prn: } y_3 \end{array} \right]$	$\left[\begin{array}{l} \text{act: strght} \\ \text{prev: left} \\ \text{next: left} \\ \text{prn: } y_4 \end{array} \right]$	$\left[\begin{array}{l} \text{act: left} \\ \text{prev: strght} \\ \text{next: strght} \\ \text{prn: } y_5 \end{array} \right]$	$\left[\begin{array}{l} \text{act: strght} \\ \text{prev: left} \\ \text{next: left} \\ \text{prn: } y_6 \end{array} \right]$	$\left[\begin{array}{l} \text{act: left} \\ \text{prev: strght} \\ \text{next:} \\ \text{prn: } y_7 \end{array} \right]$
--	---	--	--	--	--	---

6.1.4 Coding motion triggered by blue as set of proplets

$\left[\begin{array}{l} \text{rec: blue} \\ \text{prev:} \\ \text{next: strght} \\ \text{prn: } z_1 \end{array} \right]$	$\left[\begin{array}{l} \text{act: strght} \\ \text{prev: blue} \\ \text{next: right} \\ \text{prn: } z_2 \end{array} \right]$	$\left[\begin{array}{l} \text{act: right} \\ \text{prev: strght} \\ \text{next: strght} \\ \text{prn: } z_3 \end{array} \right]$	$\left[\begin{array}{l} \text{act: strght} \\ \text{prev: right} \\ \text{next: right} \\ \text{prn: } z_4 \end{array} \right]$	$\left[\begin{array}{l} \text{act: right} \\ \text{prev: strght} \\ \text{next: strght} \\ \text{prn: } z_5 \end{array} \right]$	$\left[\begin{array}{l} \text{act: strght} \\ \text{prev: right} \\ \text{next: strght} \\ \text{prn: } z_6 \end{array} \right]$	$\left[\begin{array}{l} \text{act: right} \\ \text{prev: strght} \\ \text{next:} \\ \text{prn: } z_7 \end{array} \right]$
---	---	---	--	---	---	--

6.1.5 Variable definition of the LA-act1 grammar

$T_n \in \{\text{red, green, blue}\}$ and $n \in \{1, 2, 3, \dots\}$

$M1 \in \{\text{strght, left, right}\}$

$M2 \in \{\text{strght, left, right}\}$

$K \in \{x_i, y_i, z_i, \dots\}$ and $i \in \{1, 2, 3, \dots\}$

6.1.6 Rule system of the LA-act1 grammar

$$\mathbf{ST}_S =_{def} \{ ([rec: T_n] \{Rule_0, Rule_1\}) \}$$

Rule_0 {Rule_0, Rule_1}

$\left[\begin{array}{l} rec: T_n \\ next: T_{n+1} \\ prn: K_i \end{array} \right]$	$\left[\begin{array}{l} rec: T_{n+1} \\ prev: T_n \\ prn: K_{i+1} \end{array} \right]$	output position nw
---	---	--------------------

Rule_1 {Rule_2}

$\left[\begin{array}{l} rec: T_n \\ next: M1 \\ prn: K_i \end{array} \right]$	$\left[\begin{array}{l} act: M1 \\ prev: T_n \\ prn: K_{i+1} \end{array} \right]$	output position nw
--	--	--------------------

Rule_2 {Rule_2}

$\left[\begin{array}{l} act: M1 \\ next: M2 \\ prn: K_i \end{array} \right]$	$\left[\begin{array}{l} act: M2 \\ prev: M1 \\ prn: K_{i+1} \end{array} \right]$	output position nw
---	---	--------------------

$$\mathbf{ST}_F =_{def} \{ ([next:] rp_{Rule_2}) \}$$

6.1.7 Applying Rule_1 of LA-act1 to a red trigger

rule level

Rule_1	{Rule_2}	
[rec: T _n	[
	next: M1	act: M1
	prn: K _i	prev: T _n
]]	prn: K _{i+1}

output position nw

matching and binding

Word Bank level

[rec: red	[
	prev:	act: strght
	next: strght	prev: red
	prn: x ₁	next: left
]]	prn: x ₂

6.1.8 Applying Rule_2 of LA-act1 to a strght motion

rule level

Rule_2	{Rule_2}	
[act: M1	[
	next: M2	act: M2
	prn: K _i	prev: M1
]]	prn: K _{i+1}
		output position nw

matching and binding

Word Bank level

[act: strght	[act: left
	prev: red		prev: strght
	next: left		next: right
	prn: x ₂		prn: x ₃
]]]]

6.2 Guided Patterns to Expand a Fixed Behavior Repertoire

6.2.1 New pattern for a fixed behavior agent

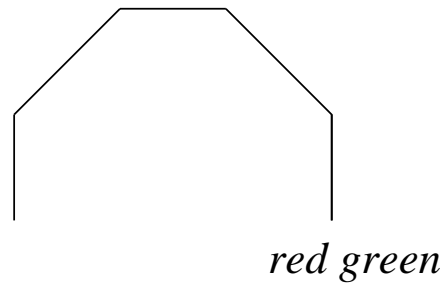

6.2.2 Coding motion triggered by red green as set of proplets

rec: red prev: next: green prn: q ₁	rec: green prev: red next: strght prn: q ₂	act: strght prev: green next: left prn: q ₃	act: left prev: strght next: left prn: q ₄	act: left prev: left next: left prn: q ₅	act: left prev: left next: left prn: q ₆	act: left prev: left next: prn: q ₇
---	--	---	--	--	--	---

6.2.3 Lexical proplets of an extended fixed behavior agent

$\left[\begin{array}{l} \text{rec: red} \\ \text{prev:} \\ \text{next:} \\ \text{prn:} \end{array} \right]$	$\left[\begin{array}{l} \text{rec: green} \\ \text{prev:} \\ \text{next:} \\ \text{prn:} \end{array} \right]$	$\left[\begin{array}{l} \text{rec: blue} \\ \text{prev:} \\ \text{next:} \\ \text{prn:} \end{array} \right]$	$\left[\begin{array}{l} \text{act: strght} \\ \text{prev:} \\ \text{next:} \\ \text{prn:} \end{array} \right]$	$\left[\begin{array}{l} \text{act: left} \\ \text{prev:} \\ \text{next:} \\ \text{prn:} \end{array} \right]$	$\left[\begin{array}{l} \text{act: right} \\ \text{prev:} \\ \text{next:} \\ \text{prn:} \end{array} \right]$
--	--	---	---	---	--

6.2.4 Recognition and lexical lookup of motion pattern 6.2.1

$\left[\begin{array}{l} \text{rec: red} \\ \text{prev:} \\ \text{next:} \\ \text{prn: q}_1 \end{array} \right]$	$\left[\begin{array}{l} \text{rec: green} \\ \text{prev:} \\ \text{next:} \\ \text{prn: q}_2 \end{array} \right]$	$\left[\begin{array}{l} \text{act: strght} \\ \text{prev:} \\ \text{next:} \\ \text{prn: q}_3 \end{array} \right]$	$\left[\begin{array}{l} \text{act: left} \\ \text{prev:} \\ \text{next:} \\ \text{prn: q}_4 \end{array} \right]$	$\left[\begin{array}{l} \text{act: left} \\ \text{prev:} \\ \text{next:} \\ \text{prn: q}_5 \end{array} \right]$	$\left[\begin{array}{l} \text{act: left} \\ \text{prev:} \\ \text{next:} \\ \text{prn: q}_6 \end{array} \right]$	$\left[\begin{array}{l} \text{act: left} \\ \text{prev:} \\ \text{next:} \\ \text{prn: q}_7 \end{array} \right]$
--	--	---	---	---	---	---

6.2.5 Rule system of the LA-rec1 grammar

$$\mathbf{ST}_S =_{def} \{ ([rec: T_n] \{Rule_0, Rule_1\}) \}$$

Rule_0 {Rule_0, Rule_1}

$$\begin{bmatrix} rec: T_n \\ next: \\ prn: K_i \end{bmatrix} \begin{bmatrix} rec: T_{n+1} \\ prev: \\ prn: K_{i+1} \end{bmatrix} \Rightarrow \begin{bmatrix} rec: T_n \\ next: T_{n+1} \\ prn: K_i \end{bmatrix} \begin{bmatrix} rec: T_{n+1} \\ prev: T_n \\ prn: K_{i+1} \end{bmatrix}$$

Rule_1 {Rule_2}

$$\begin{bmatrix} rec: T_n \\ next: \\ prn: K_i \end{bmatrix} \begin{bmatrix} act: M1 \\ prev: \\ prn: K_{i+1} \end{bmatrix} \Rightarrow \begin{bmatrix} rec: T_n \\ next: M1 \\ prn: K_i \end{bmatrix} \begin{bmatrix} act: M1 \\ prev: T_n \\ prn: K_{i+1} \end{bmatrix}$$

Rule_2 {Rule_2}

$$\begin{bmatrix} act: M1 \\ next: \\ prn: K_i \end{bmatrix} \begin{bmatrix} act: M2 \\ prev: \\ prn: K_{i+1} \end{bmatrix} \Rightarrow \begin{bmatrix} act: M1 \\ next: M2 \\ prn: K_i \end{bmatrix} \begin{bmatrix} act: M2 \\ prev: M1 \\ prn: K_{i+1} \end{bmatrix}$$

$$\mathbf{ST}_F =_{def} \{ ([next:] rp_{Rule_2}) \}$$

6.3 Transition from Fixed to Adaptive Behavior

6.3.1 Extensions required by an adaptive behavior agent

1. Writable memory

In order to record individual recognition action episodes, the agent's non-writable memory must be complemented with a writable memory.

2. Decoupling of recognition and action

The agent must be capable of recognition without having to perform the associated fixed behavior action (*recognition per se*), just as there must be action triggered by reasoning rather than by a fixed behavior stimulus.

3. Unknowns

The agent must be able to recognize and store unknowns consisting of previously unencountered constellations of available recognition elements.

4. Appraisal

In order to learn from past experiences, the agent must be able to evaluate the implication of recognitions and the outcome of actions.

5. Automatic schema derivation

In order to generalize over similar constellations, the agent must be capable of automatic schema derivation.

6.3.2 Arrangement of writable and non-writable memory

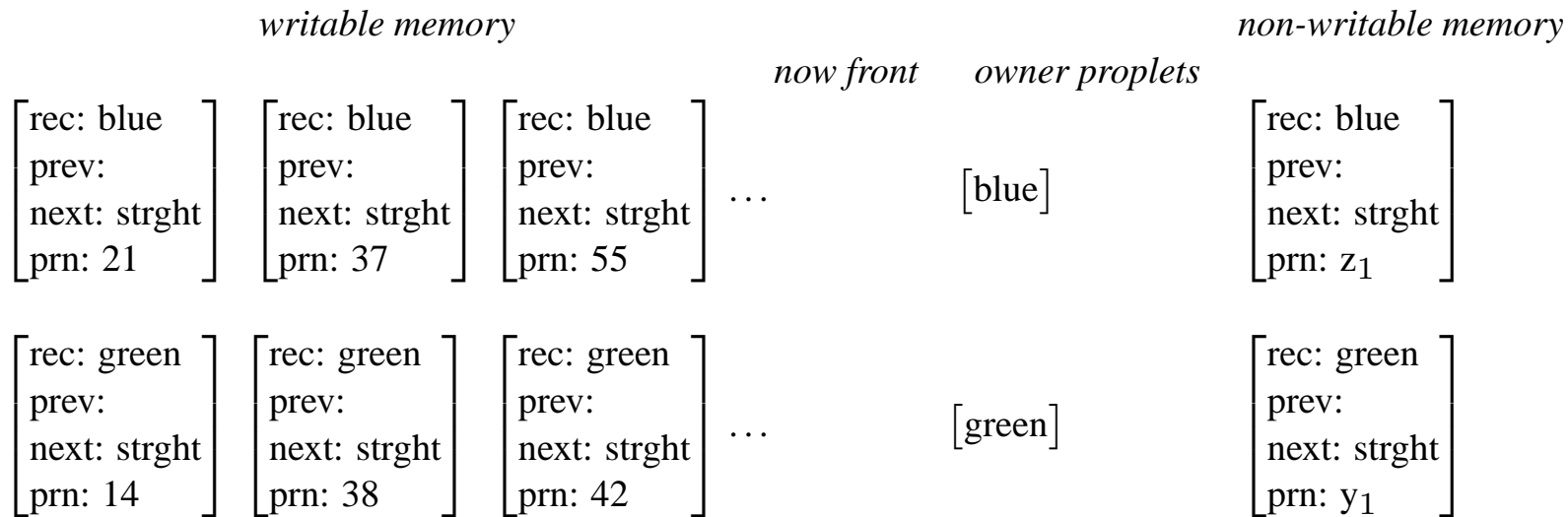

6.3.3 Two simple R/E one-step inference chains

R/E [rec: red square] K cm/exec [act: feed] K+1

R/E [rec: green circle] K cm/exec [act: hide] K+1

6.3.4 Decoupled recognitions and actions

rec: red act: hide

rec: green act: feed

rec: square

rec: circle

6.3.5 Possible constellations when faced with an unknown

1 rec: red circle act: hide rec: good

2 rec: red circle act: hide rec: bad

3 rec: red circle act: feed rec: good

4 rec: red circle act: feed rec: bad

6.3.6 Consequence inference for negative experience (CIN)

rec: α act: β rec: bad csq rec: α act: no β

6.3.7 Consequence inference for positive experience (CIP)

rec: α act: β rec: good csq rec: α act: β

6.4 Upscaling from Coordination to Functor-Argument

6.4.1 Use of propositional calculus in predicate calculus

$$[p \wedge q] \implies \exists x[\text{red}(x) \wedge \text{circle}(x)]$$

6.4.2 Integrating functor-argument in DBS

$$\begin{array}{l}
 \left[\begin{array}{l} \text{rec: red} \\ \text{next: circle} \\ \text{prev:} \\ \text{prn: 62} \end{array} \right] \quad \left[\begin{array}{l} \text{rec: circle} \\ \text{next:} \\ \text{prev: red} \\ \text{prn: 62} \end{array} \right] \implies \left[\begin{array}{l} \text{adj: red} \\ \text{cat: adn} \\ \text{mdd: circle} \\ \text{nc:} \\ \text{pc:} \\ \text{prn: 62} \end{array} \right] \quad \left[\begin{array}{l} \text{noun: circle} \\ \text{cat: sn} \\ \text{mdr: red} \\ \text{nc:} \\ \text{pc:} \\ \text{prn: 62} \end{array} \right]
 \end{array}$$

6.4.3 Coding nonlanguage and language content alike

	<i>member proplets</i>	<i>now front</i>	<i>owner proplets</i>
...	<div style="border-left: 1px solid black; border-right: 1px solid black; padding: 5px; display: inline-block;"> sur: noun: circle cat: pnp sem: pl sel fnc: mdr: red nc: pc: prn: 37 </div>	...	<div style="border-left: 1px solid black; border-right: 1px solid black; padding: 5px; display: inline-block;"> sur: circles noun: (circle 37) cat: pnp sem: pl sel fnc: mdr: (red 37) nc: pc: prn: 62 </div>
			...
			[core: circle]
...	<div style="border-left: 1px solid black; border-right: 1px solid black; padding: 5px; display: inline-block;"> sur: adj: red cat: adn sem: psv mdd: circle nc: pc: prn: 37 </div>	...	<div style="border-left: 1px solid black; border-right: 1px solid black; padding: 5px; display: inline-block;"> sur: red adj: (red 37) cat: adn sem: psv mdd: (circle 37) nc: pc: prn: 62 </div>
			[core: red]

6.4.4 The Fifth Mechanism of Communication (MoC-5)

Exporting coordination and functor-argument from language content to nonlanguage (context) content, coded uniformly as sets of proplets, allows us to model *reference* as a pattern matching between language content and context content in the hear mode, and between context content and language content in the speak mode.

6.5 Schema Derivation and Hierarchy Inferencing

6.5.1 Converting a content into an equivalent schema

<i>content</i>	$\left[\begin{array}{l} \text{noun: child} \\ \text{cat: snp} \\ \text{sem: pl exh} \\ \text{fnc: sleep} \\ \text{mdr:} \\ \text{nc:} \\ \text{pc:} \\ \text{prn: 26} \end{array} \right]$	$\left[\begin{array}{l} \text{verb: sleep} \\ \text{cat: decl} \\ \text{sem: past} \\ \text{arg: child} \\ \text{mdr:} \\ \text{nc: (snore 27)} \\ \text{pc:} \\ \text{prn: 26} \end{array} \right]$	$\left[\begin{array}{l} \text{noun: Fido} \\ \text{cat: nm} \\ \text{sem: animal} \\ \text{fnc: snore} \\ \text{mdr:} \\ \text{nc:} \\ \text{pc:} \\ \text{prn: 27} \end{array} \right]$	$\left[\begin{array}{l} \text{verb: snore} \\ \text{cat: decl} \\ \text{sem: past} \\ \text{arg: Fido} \\ \text{mdr:} \\ \text{nc:} \\ \text{pc: (sleep 26)} \\ \text{prn: 27} \end{array} \right]$
----------------	---	---	---	--

\Leftrightarrow

<i>schema</i>	$\left[\begin{array}{l} \text{noun: } \alpha \\ \text{cat: snp} \\ \text{sem: pl exh} \\ \text{fnc: } \beta \\ \text{mdr:} \\ \text{nc:} \\ \text{pc:} \\ \text{prn: K} \end{array} \right]$	$\left[\begin{array}{l} \text{verb: } \beta \\ \text{cat: decl} \\ \text{sem: past} \\ \text{arg: } \alpha \\ \text{mdr:} \\ \text{nc: (} \delta \text{ K+1)} \\ \text{pc:} \\ \text{prn: K} \end{array} \right]$	$\left[\begin{array}{l} \text{noun: } \gamma \\ \text{cat: nm} \\ \text{sem: animal} \\ \text{fnc: } \delta \\ \text{mdr:} \\ \text{nc:} \\ \text{pc:} \\ \text{prn: K+1} \end{array} \right]$	$\left[\begin{array}{l} \text{verb: } \delta \\ \text{cat: decl} \\ \text{sem: past} \\ \text{arg: } \gamma \\ \text{mdr:} \\ \text{nc:} \\ \text{pc: (} \beta \text{ K)} \\ \text{prn: K+1} \end{array} \right]$
---------------	---	--	---	--

where $\alpha \in \{\text{child}\}$, $\beta \in \{\text{sleep}\}$,
 $\gamma \in \{\text{Fido}\}$, $\delta \in \{\text{snore}\}$, and
 $K \in \{26\}$

6.5.2 Converting a schema into equivalent contents

<i>schema</i>	$\left[\begin{array}{l} \text{noun: } \alpha \\ \text{cat: snp} \\ \text{sem: pl exh} \\ \text{fnc: } \beta \\ \text{mdr:} \\ \text{nc:} \\ \text{pc:} \\ \text{prn: K} \end{array} \right]$	$\left[\begin{array}{l} \text{verb: } \beta \\ \text{cat: decl} \\ \text{sem: past} \\ \text{arg: } \alpha \\ \text{mdr:} \\ \text{nc:} \\ \text{pc:} \\ \text{prn: K} \end{array} \right]$	<p>where $\alpha \in \{\text{man, woman, child}\}$, $\beta \in \{\text{sleep, sing, dream}\}$ and $K \in \mathbb{N}$</p>
\iff			
<i>content</i>	<p>Every man slept. Every woman slept. Every child slept.</p>	<p>Every man sang. Every woman sang. Every child sang.</p>	<p>Every man dreamed. Every woman dreamed. Every child dreamed.</p>

6.5.3 Set of contents with partial overlap

Julia eats an apple	John eats an apple	Suzy eats an apple	Bill eats an apple
Julia eats a pear	John eats a pear	Suzy eats a pear	Bill eats a pear
Julia eats a salad	John eats a salad	Suzy eats a salad	Bill eats a salad
Julia eats a steak	John eats a steak	Suzy eats a steak	Bill eats a steak

6.5.4 Summarizing the set 6.5.3 as a schema

$$\begin{bmatrix} \text{noun: } \alpha \\ \text{fnc: eat} \\ \text{prn: K} \end{bmatrix} \quad \begin{bmatrix} \text{verb: eat} \\ \text{arg: } \alpha \beta \\ \text{prn: K} \end{bmatrix} \quad \begin{bmatrix} \text{noun: } \beta \\ \text{fnc: eat} \\ \text{prn: K} \end{bmatrix}$$

where $\alpha \in \{\text{Julia, John, Suzy, Bill}\}$ and $\beta \in \{\text{apple, pear, salad, steak}\}$

6.5.5 Coding the subclass relation for food

[noun: food]
fnc: β
prn: K

where $food \in \{\text{apple, pear, salad, steak}\}$

6.5.6 Representing the semantic hierarchy 6.5.5 as a tree

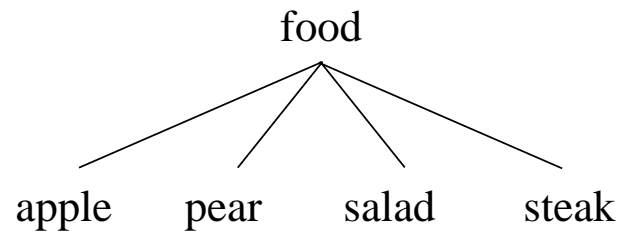

6.5.7 Meta-inference deriving down and up inferences

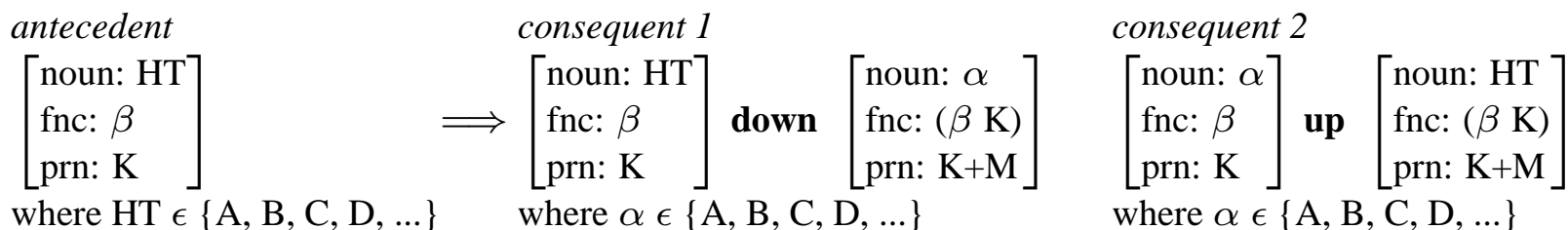

6.5.8 Applying meta-inference 6.5.7 to derive down inference

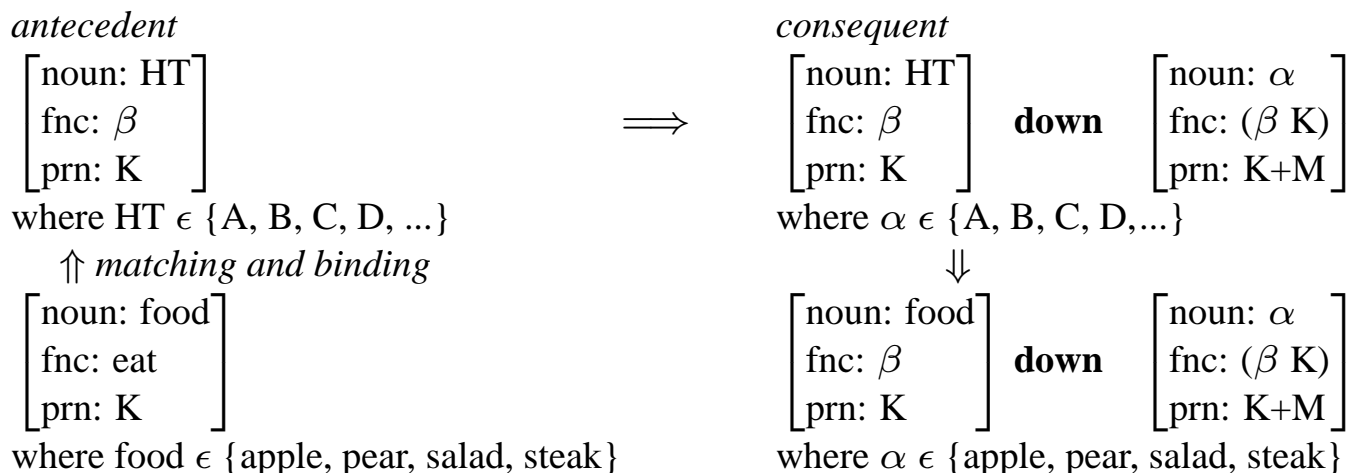

6.5.9 Applying inference for downward traversal

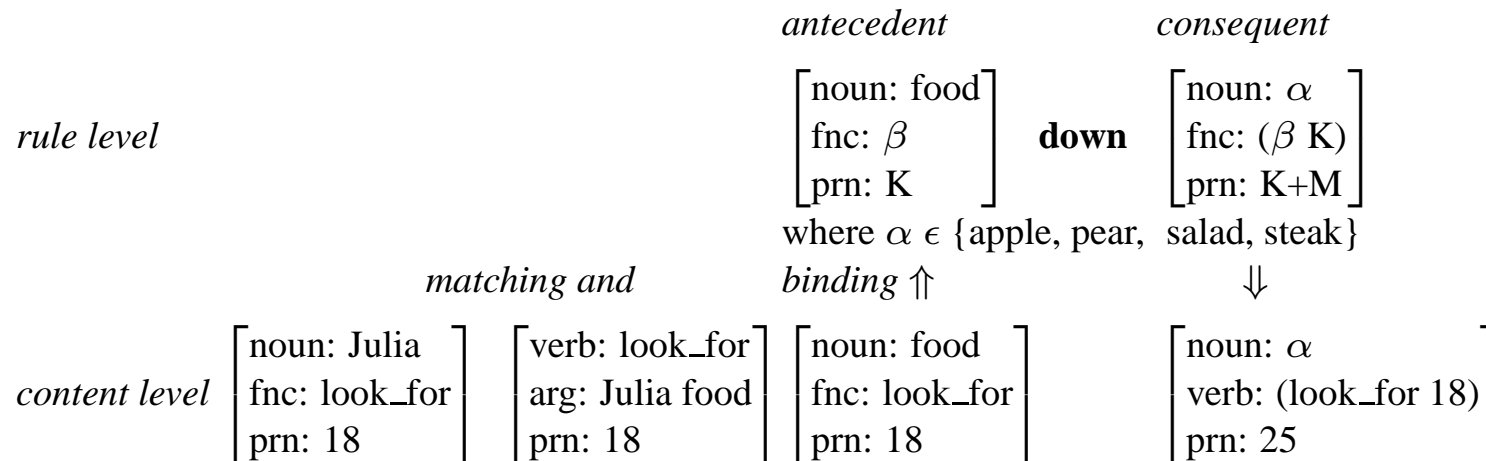

6.5.10 Output disjunction of the downward inference 6.5.8

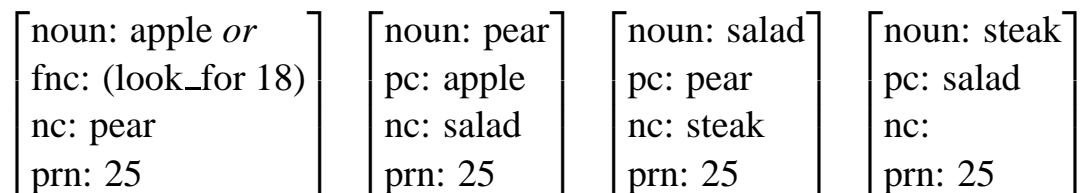

6.5.11 Proposition resulting from downward inference 6.5.9

[noun: (Julia 18) fnc: (look_for 18) prn: 25	[verb: (look_for 18) arg: (Julia 18) apple or prn: 25	[noun: apple or fnc: (look_for 18) nc: pear prn: 25	[noun: pear pc: apple nc: salad prn: 25	[noun: salad pc: pear nc: steak prn: 25	[noun: steak pc: salad nc: prn: 25
--	---	--	--	--	---

6.5.12 Hierarchy-inference for upward traversal

<i>antecedent</i>	<i>consequent</i>														
<i>rule level</i> $\alpha \in \{\text{apple, pear, salad, steak}\}$ & <table style="border: 1px solid black; padding: 5px; display: inline-table; vertical-align: middle;"> <tr><td>noun: α</td></tr> <tr><td>fnc: β</td></tr> <tr><td>prn: K</td></tr> </table> up	noun: α	fnc: β	prn: K	<table style="border: 1px solid black; padding: 5px; display: inline-table; vertical-align: middle;"> <tr><td>noun: food</td></tr> <tr><td>fnc: (β K)</td></tr> <tr><td>prn: K+M</td></tr> </table>	noun: food	fnc: (β K)	prn: K+M								
noun: α															
fnc: β															
prn: K															
noun: food															
fnc: (β K)															
prn: K+M															
<i>matching and binding</i>															
<i>content level</i> <table style="border: 1px solid black; padding: 5px; display: inline-table; vertical-align: middle;"> <tr><td>noun: Julia</td></tr> <tr><td>fnc: prepare</td></tr> <tr><td>prn: 23</td></tr> </table>	noun: Julia	fnc: prepare	prn: 23	<table style="border: 1px solid black; padding: 5px; display: inline-table; vertical-align: middle;"> <tr><td>verb: prepare</td></tr> <tr><td>arg: Julia salad</td></tr> <tr><td>prn: 23</td></tr> </table>	verb: prepare	arg: Julia salad	prn: 23	<table style="border: 1px solid black; padding: 5px; display: inline-table; vertical-align: middle;"> <tr><td>noun: salad</td></tr> <tr><td>fnc: prepare</td></tr> <tr><td>prn: 23</td></tr> </table>	noun: salad	fnc: prepare	prn: 23	<table style="border: 1px solid black; padding: 5px; display: inline-table; vertical-align: middle;"> <tr><td>noun: food</td></tr> <tr><td>fnc: (prepare 23)</td></tr> <tr><td>prn: 29</td></tr> </table>	noun: food	fnc: (prepare 23)	prn: 29
noun: Julia															
fnc: prepare															
prn: 23															
verb: prepare															
arg: Julia salad															
prn: 23															
noun: salad															
fnc: prepare															
prn: 23															
noun: food															
fnc: (prepare 23)															
prn: 29															

6.6 Natural vs. Artificial Language Learning

6.6.1 One proplet shell taking different core values

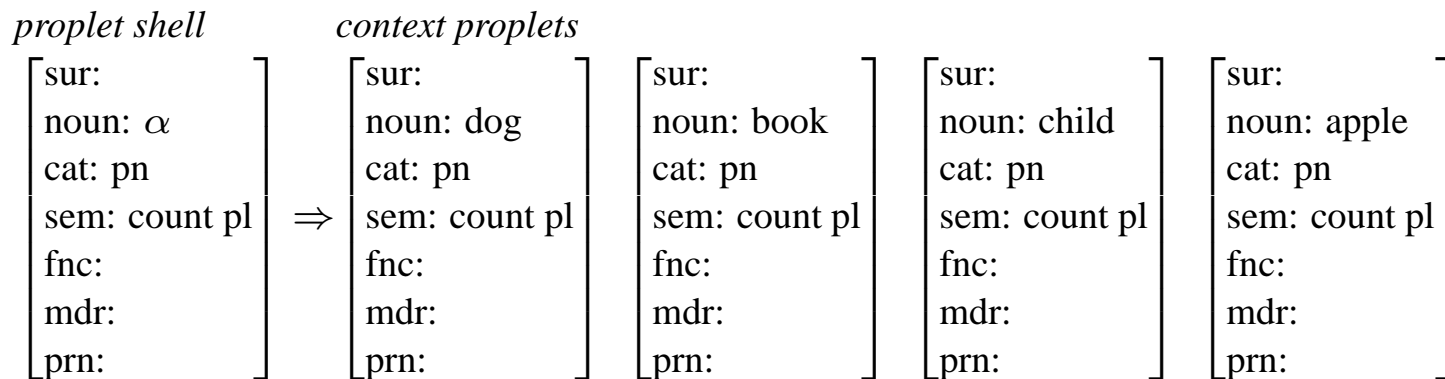

6.6.2 Turning context proplets into language proplets

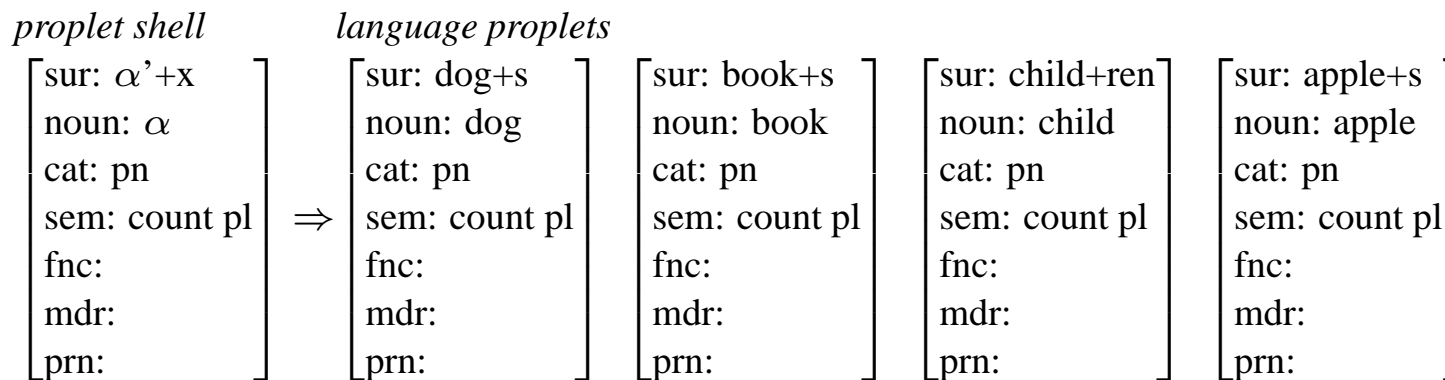

6.6.3 Taking sur values from different languages

<i>proplet shell</i>		<i>language proplets</i>			
$\left[\begin{array}{l} \text{sur: } \alpha' \\ \text{noun: } \alpha \\ \text{cat: sn} \\ \text{sem: count sg} \\ \text{fnc:} \\ \text{mdr:} \\ \text{prn:} \end{array} \right]$	\Rightarrow	$\left[\begin{array}{l} \text{sur: dog} \\ \text{noun: dog} \\ \text{cat: sn} \\ \text{sem: count sg} \\ \text{fnc:} \\ \text{mdr:} \\ \text{prn:} \end{array} \right]$	$\left[\begin{array}{l} \text{sur: chien} \\ \text{noun: dog} \\ \text{cat: sn} \\ \text{sem: count sg} \\ \text{fnc:} \\ \text{mdr:} \\ \text{prn:} \end{array} \right]$	$\left[\begin{array}{l} \text{sur: Hund} \\ \text{noun: dog} \\ \text{cat: sn} \\ \text{sem: count sg} \\ \text{fnc:} \\ \text{mdr:} \\ \text{prn:} \end{array} \right]$	$\left[\begin{array}{l} \text{sur: cane} \\ \text{noun: dog} \\ \text{cat: sn} \\ \text{sem: count sg} \\ \text{fnc:} \\ \text{mdr:} \\ \text{prn:} \end{array} \right]$

6.6.4 Examples using *book* in different parts of speech

Mary loves a good *book* (noun).

Mary *booked* (verb) a flight to Paris.

Mary is a rather *bookish* (adj) girl.

6.6.5 Core value *book* in noun, verb, and adj proplets

<i>book</i> \implies	$\left[\begin{array}{l} \text{sur: book} \\ \text{noun: book} \\ \text{cat: sn} \\ \text{sem: count sg} \\ \text{fnc:} \\ \text{mdr:} \\ \text{prn:} \end{array} \right]$	$\left[\begin{array}{l} \text{sur: booked} \\ \text{verb: book} \\ \text{cat: n' a' v} \\ \text{sem: past} \\ \text{fnc:} \\ \text{mdr:} \\ \text{prn:} \end{array} \right]$	$\left[\begin{array}{l} \text{sur: bookish} \\ \text{adj: book} \\ \text{cat: adn} \\ \text{sem: psv} \\ \text{mdd:} \\ \text{prn:} \end{array} \right]$
------------------------	--	---	---

6.6.6 Examples using *red* and *square* in different parts of speech

Mary preferred the other *red* (noun).

The rising sun *reddened* (verb) the sky.

Mary drank *red* (adj) wine.

Mary's house faces a *square* (noun).

Mary *squared* (verb) her account.

Mary bought a *square* (adj) table.

6.6.7 Core values in syntactic-semantic composition

book_V the red_A square_N

book_V the square_N red_A

book_V the square_A red_N

square_V the red_A book_N

square_V the book_N red_A

square_V the book_A red_N

redde_N the square_A book_N

redde_N the book_N square_A

redde_N the book_N square_N

etc.

6.6.8 Cognitive procedures using placeholder core values

1. The time-linear syntactic-semantic *interpretation* in the hear mode,
2. the *storage* of content provided by recognition and inferencing in the Word Bank,
3. the navigation-based semantic-syntactic *production* in the speak mode,
4. the definition of such *meaning relations* as synonymy, antonymy, hypernymy, hyponymy, meronymy, and holonymy as well as cause-effect,
5. the design and implementation of reactor, deductor, and effector *inferences*,
6. the design and implementation of language inferences for adjusting *perspective*,
and
7. the *interaction* between the context and language levels

6.6.9 Learning a new word

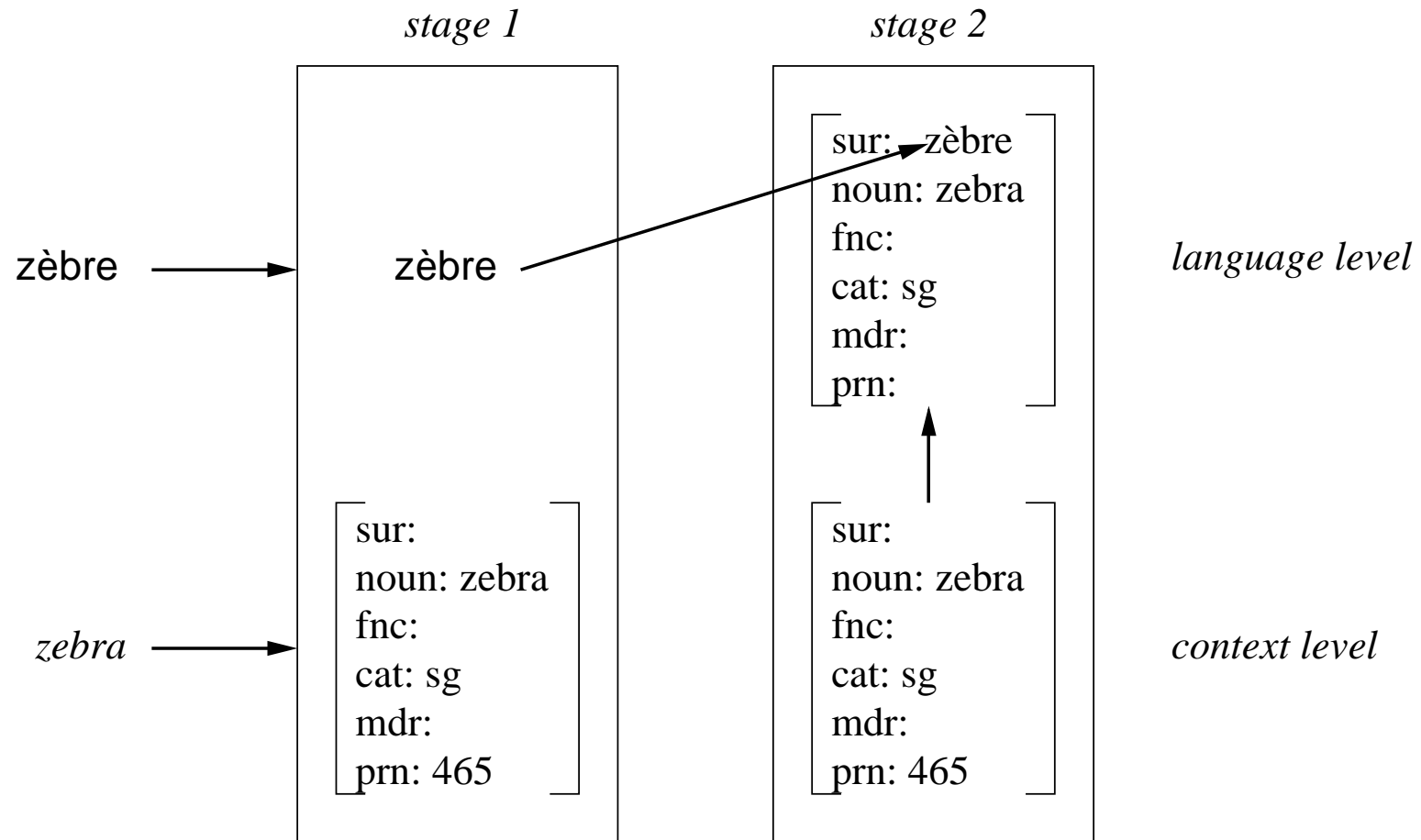

Part II.

The Coding of Content

7. Compositional Semantics

7.1 Forms of Graphical Representation

7.1.1 Comparing representations of the subject-verb relation

Julia slept

Phrase Structure Grammar

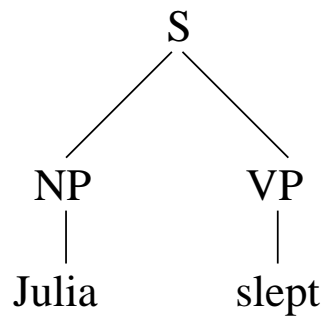

Dependency Grammar



DBS

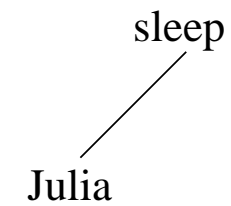

7.1.2 Comparing determiner-adjective-noun constructions

The little girl slept.

Phrase Structure Grammar

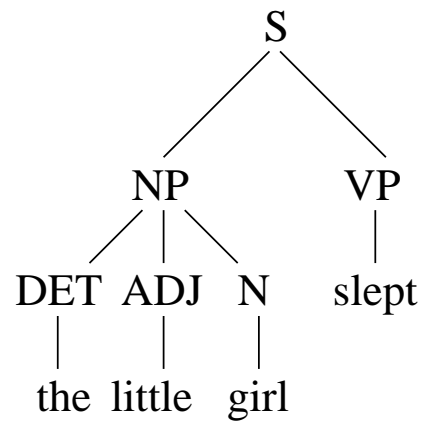

Dependency Grammar

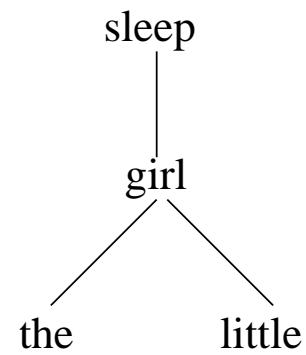

DBS

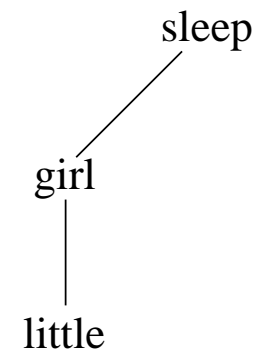

7.2 Absorption and Precipitation of Function Words

7.2.1 Function words with different lexical readings

- 1a. Mary has a house *by* the lake.
- 1b. The book was read *by* Mary.
- 2a. Mary moved *to* Paris.
- 2b. Mary tried *to* sleep.

7.2.2 Correlating elementary/phrasal surfaces and contents

elementary surface

Julia

phrasal surface

the girl

phrasal surface

the little girl

elementary content

noun: Julia
cat: nm
sem: sg
fnc: sleep
mdr:
prn: 1

elementary content

noun: girl
cat: snp
sem: def sg
fnc: sleep
mdr:
prn: 2

phrasal content

noun: girl
cat: snp
sem: def sg
fnc: sleep
mdr: little
prn: 3

noun: little
cat: adn
sem: psv
mdd: girl
nc:
prn: 3

7.2.3 Hear mode derivation of The little girl ate an apple.

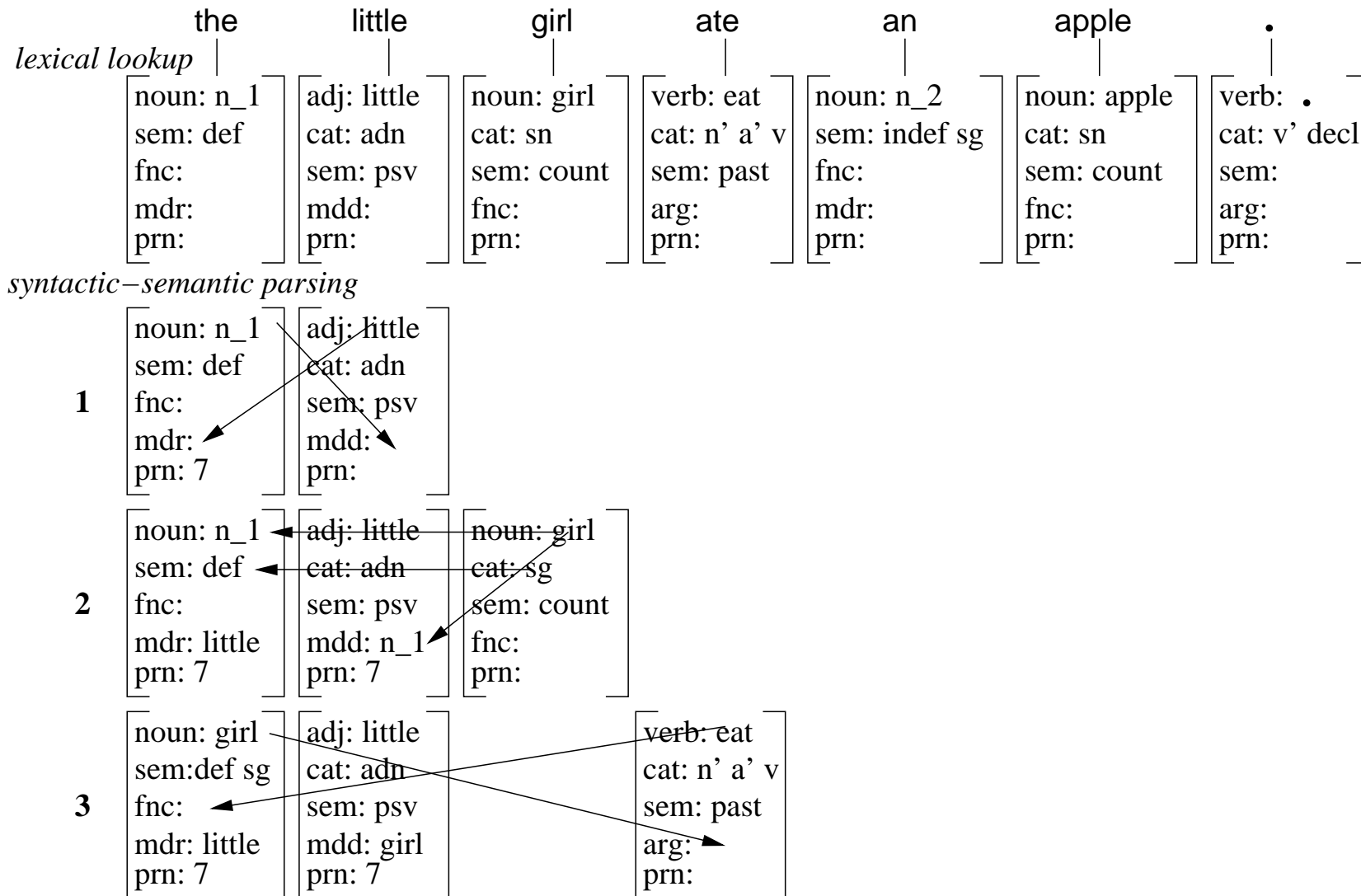

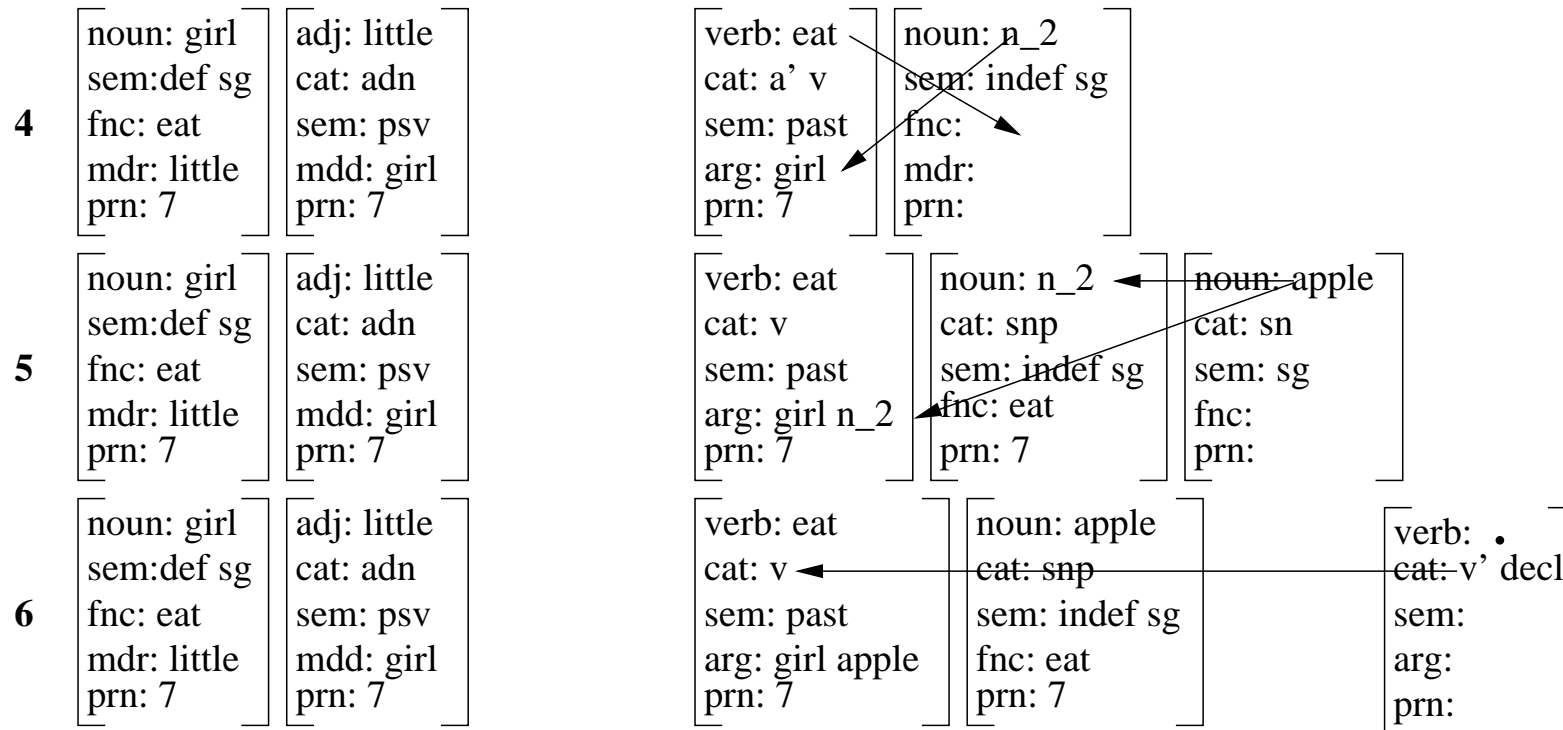

resulting content

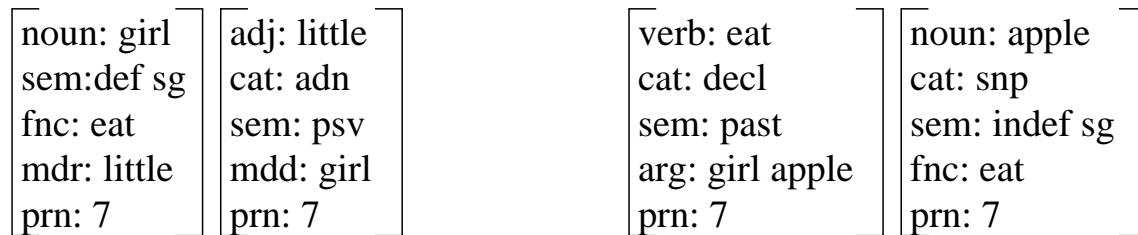

7.2.4 Comparing different function word absorptions

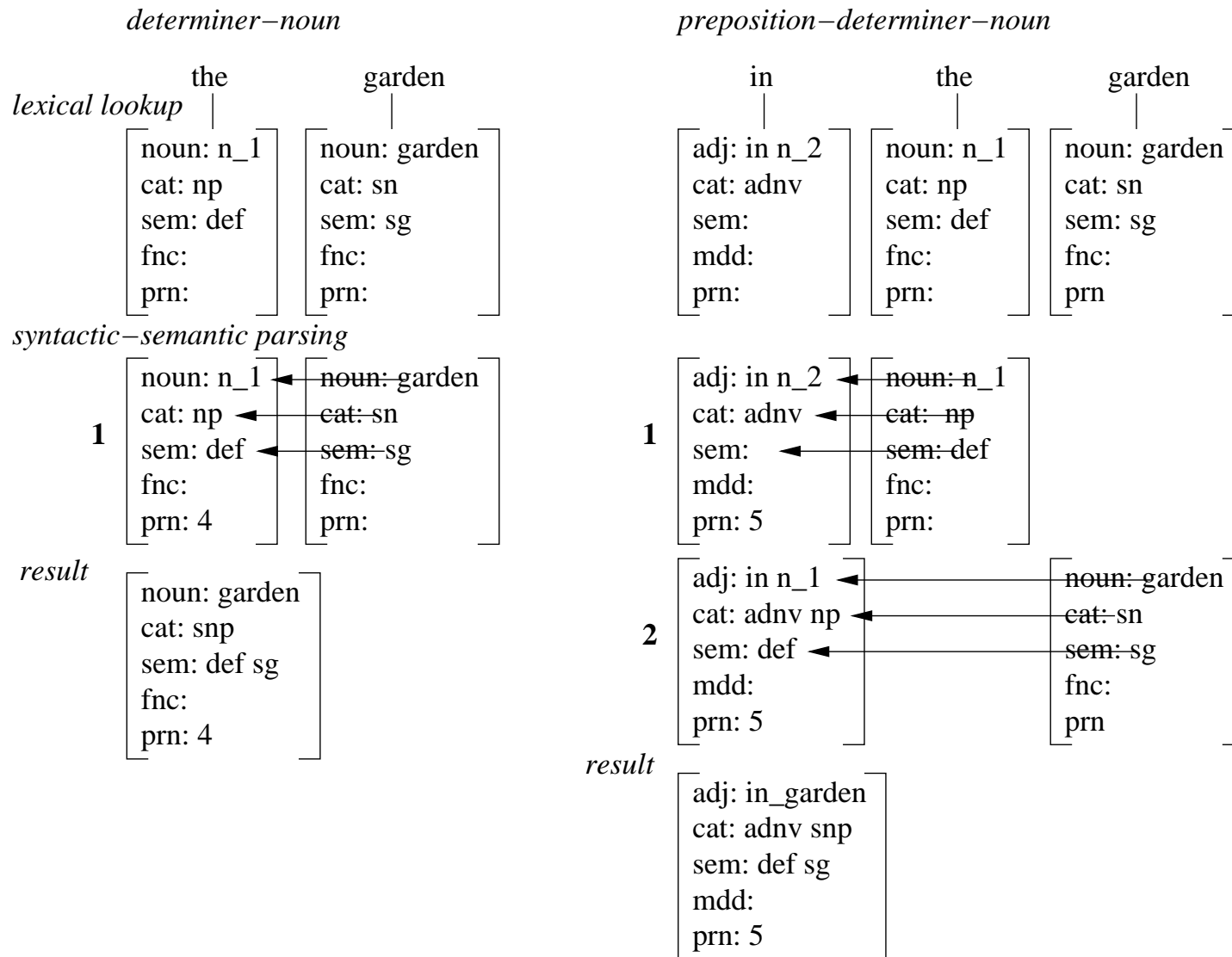

7.2.5 Prepositional phrase as elementary adjective

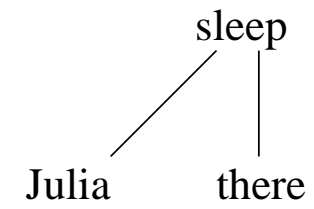
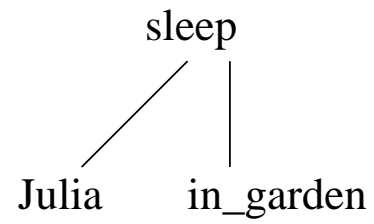
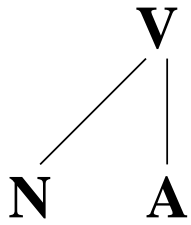

7.3 Deriving DBS Graphs from Sets of Proplets

7.3.1 On relating proplet sets to DBS graphs

- What is the nature of the relation between the proplet representation of a content and the corresponding SRG or signature?
- Can an SRG or a signature be derived automatically from a set of proplets representing a certain content?

7.3.2 Content corresponding to The little girl ate an apple.

$\left[\begin{array}{l} \text{noun: girl} \\ \text{sem: def sg} \\ \text{fnc: eat} \\ \text{mdr: little} \\ \text{prn: 7} \end{array} \right]$	$\left[\begin{array}{l} \text{adj: little} \\ \text{cat: adn} \\ \text{sem: psv} \\ \text{mdd: girl} \\ \text{prn: 7} \end{array} \right]$	$\left[\begin{array}{l} \text{verb: eat} \\ \text{cat: decl} \\ \text{sem: past} \\ \text{arg: girl apple} \\ \text{prn: 7} \end{array} \right]$	$\left[\begin{array}{l} \text{noun: apple} \\ \text{cat: snp} \\ \text{sem: indef sg} \\ \text{fnc: eat} \\ \text{prn: 7} \end{array} \right]$
---	---	---	---

7.3.3 Schemata interpreting transparent intraprop. relations

(1) noun/verb

 $\left[\begin{array}{l} \text{noun: } \alpha \\ \text{fnc: } \beta \end{array} \right] \left[\begin{array}{l} \text{verb: } \beta \\ \text{arg: } \alpha \text{ X} \end{array} \right]$

(2) noun \ verb

 $\left[\begin{array}{l} \text{noun: } \alpha \\ \text{fnc: } \beta \end{array} \right] \left[\begin{array}{l} \text{verb: } \beta \\ \text{arg: } \gamma \text{ X } \alpha \end{array} \right]$

(3) adjective|noun

 $\left[\begin{array}{l} \text{adj: } \alpha \\ \text{mdd: } \beta \end{array} \right] \left[\begin{array}{l} \text{noun: } \beta \\ \text{mdr: X } \alpha \text{ Y} \end{array} \right]$

(4) adjective|verb

 $\left[\begin{array}{l} \text{adj: } \alpha \\ \text{mdd: } \beta \end{array} \right] \left[\begin{array}{l} \text{verb: } \beta \\ \text{mdr: X } \alpha \text{ Y} \end{array} \right]$

(5) noun— noun

 $\left[\begin{array}{l} \text{noun: } \alpha \\ \text{nc: } \beta \end{array} \right] \left[\begin{array}{l} \text{noun: } \beta \\ \text{pc: } \alpha \end{array} \right]$

(6) verb—verb

 $\left[\begin{array}{l} \text{verb: } \alpha \\ \text{nc: } \beta \end{array} \right] \left[\begin{array}{l} \text{verb: } \beta \\ \text{pc: } \alpha \end{array} \right]$

(7) adjective—adjective

 $\left[\begin{array}{l} \text{adj: } \alpha \\ \text{nc: } \beta \end{array} \right] \left[\begin{array}{l} \text{adj: } \beta \\ \text{pc: } \alpha \end{array} \right]$

7.3.4 DBS graph based on proplets (proplet graph)

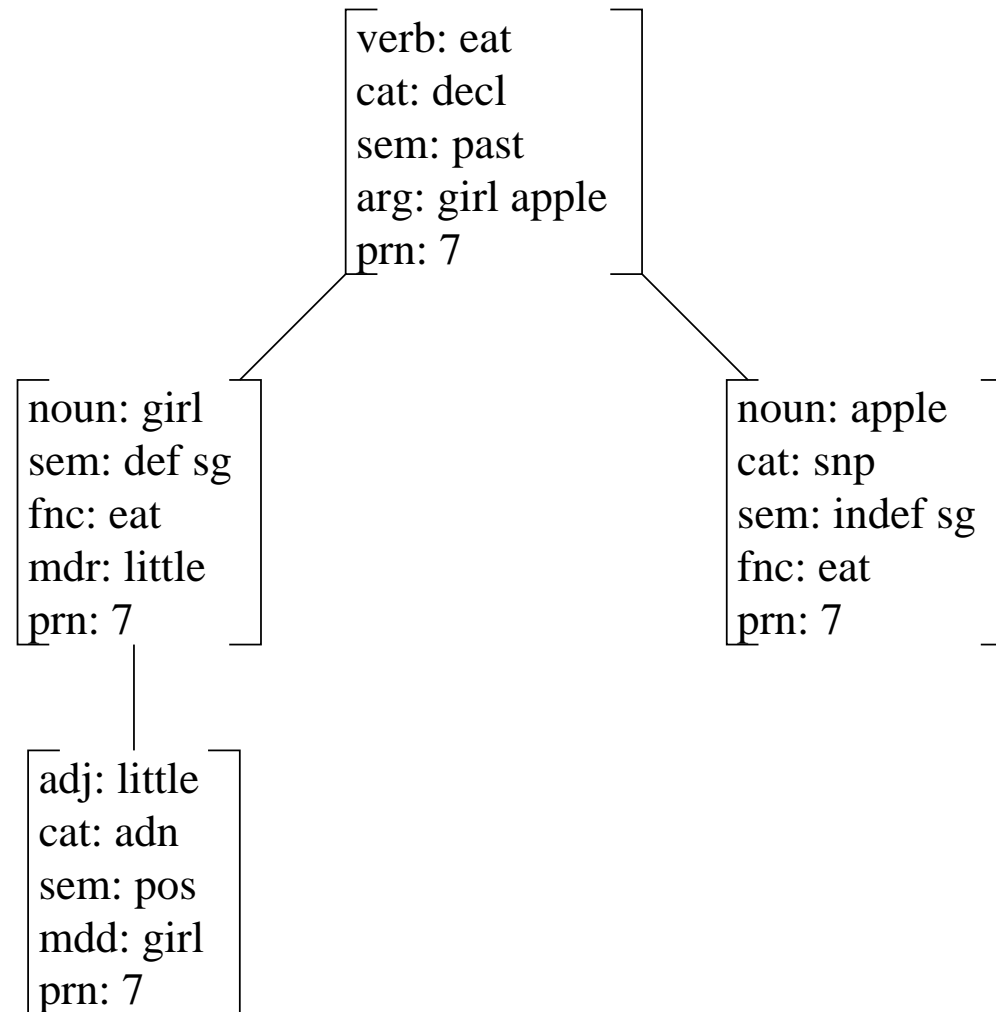

7.3.5 Resulting SRG and signature

(i) *semantic relations graph (SRG)*

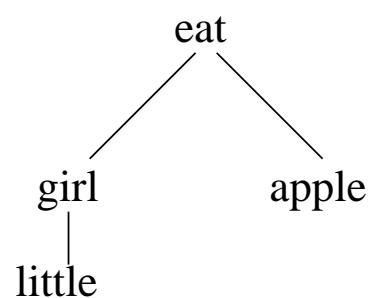

(ii) *signature*

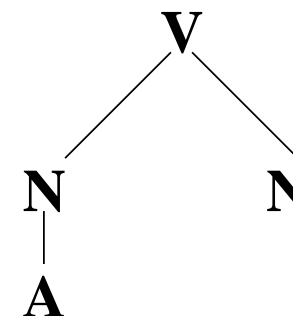

7.3.6 The seven transparent semantic relations of structure

- subject-verb: 1. N/V
- object-verb: 2. N\V
- adjective-noun: 3. A|N
- adjective-verb: 4. A|V
- conjunct-conjunct: 5. N–N
- 6. V–V
- 7. A–A

7.4 Producing Natural Language Surfaces from Content

7.4.1 The four DBS views on a content and its surface

(i) *semantic relations graph (SRG)*

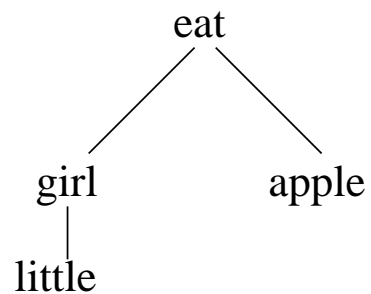

(iii) *numbered arcs graph (NAG)*

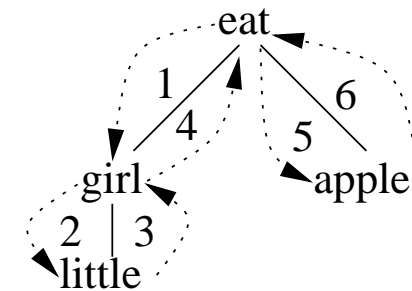

(ii) *signature*

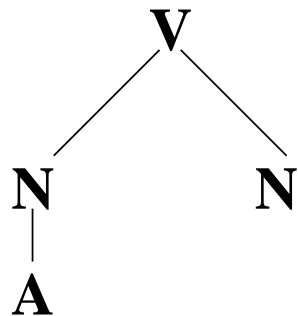

(iv) *surface realization*

1	2	3	4	5	6
The	little	girl	ate	an__apple	.

7.4.2 Numbered arcs graph based on proplets (proplet NAG)

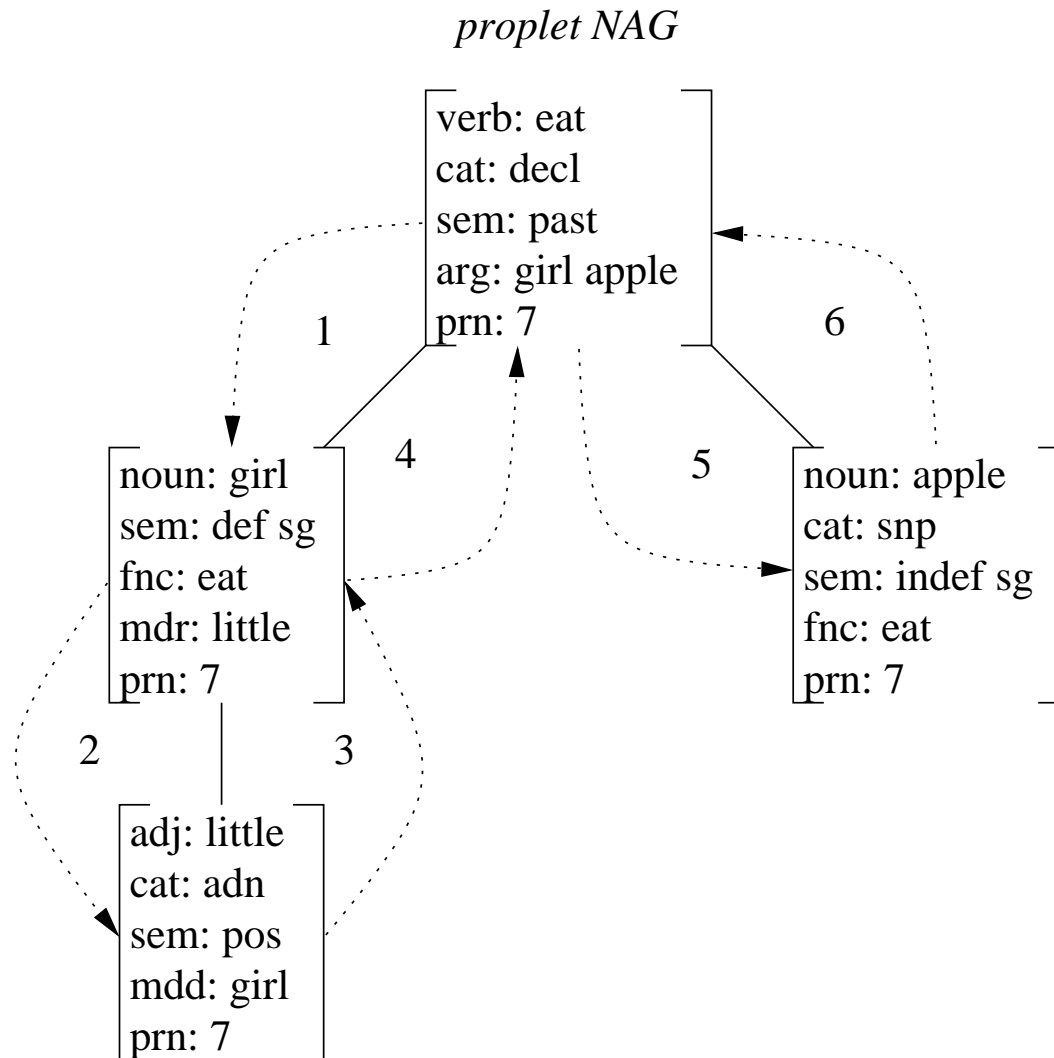

7.4.3 LA-speak grammar for the proplet NAG 7.4.2

	0. START	{DET-ADN, DET-CN }	
<i>rule level</i>	$\left[\begin{array}{l} \text{verb: } \alpha \\ \text{arg: X} \\ \text{prn: K} \end{array} \right]$		
<i>content level</i>	$\left[\begin{array}{l} \text{verb: eat} \\ \text{cat: decl} \\ \text{sem: past} \\ \text{arg: girl apple} \\ \text{prn: 7} \end{array} \right]$		
	1. DET-ADN	{ADN}	
<i>rule level</i>	$\left[\begin{array}{l} \text{verb: } \alpha \\ \text{arg: X } \beta \text{ Y} \\ \text{prn: K} \end{array} \right]$	$\left[\begin{array}{l} \text{noun: } \beta \\ \text{sem: } \gamma \\ \text{fnc: } \alpha \\ \text{mdr: } \delta \\ \text{prn: K} \end{array} \right]$	the ↑ ⇒ lex(γ)
<i>content level</i>	$\left[\begin{array}{l} \text{verb: eat} \\ \text{cat: decl} \\ \text{sem: past} \\ \text{arg: girl apple} \\ \text{prn: 7} \end{array} \right]$	$\left[\begin{array}{l} \text{noun: girl} \\ \text{sem: def sg} \\ \text{fnc: eat} \\ \text{mdr: little} \\ \text{prn: 7} \end{array} \right]$	

2. ADN {CN}

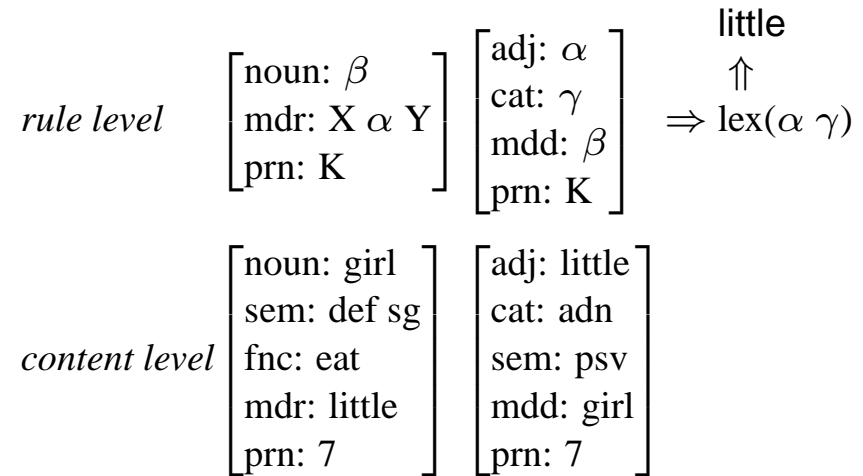

3. CN {FV, PNC}

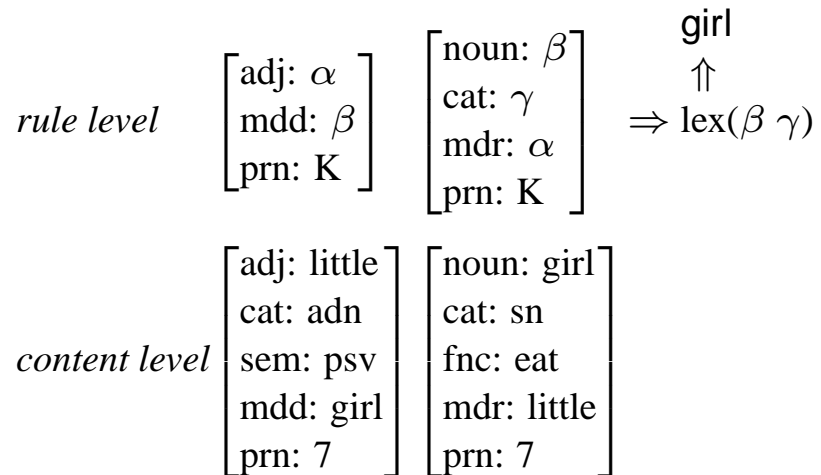

4. FV {DET-ADJ, DET-CN}

<i>rule level</i>	$\left[\begin{array}{l} \text{noun: } \beta \\ \text{fnc: } \alpha \\ \text{prn: K} \end{array} \right]$	$\left[\begin{array}{l} \text{verb: } \alpha \\ \text{arg: } \beta \text{ Y} \\ \text{sem: } \gamma \\ \text{prn: K} \end{array} \right]$	ate ↑ ⇒ lex($\alpha \gamma$)
<i>content level</i>	$\left[\begin{array}{l} \text{noun: girl} \\ \text{sem: def sg} \\ \text{fnc: eat} \\ \text{mdr: little} \\ \text{prn: 7} \end{array} \right]$	$\left[\begin{array}{l} \text{verb: eat} \\ \text{cat: decl} \\ \text{sem: past} \\ \text{arg: girl apple} \\ \text{prn: 7} \end{array} \right]$	

5. DET-CN {FV, PNC}

<i>rule level</i>	$\left[\begin{array}{l} \text{verb: } \alpha \\ \text{arg: X } \beta \text{ Y} \\ \text{prn: K} \end{array} \right]$	$\left[\begin{array}{l} \text{noun: } \beta \\ \text{sem: } \gamma \\ \text{fnc: } \alpha \\ \text{mdr: NIL} \\ \text{prn: K} \end{array} \right]$	an apple ↑ ⇒ lex($\gamma \beta$)
<i>content level</i>	$\left[\begin{array}{l} \text{verb: eat} \\ \text{cat: decl} \\ \text{sem: past} \\ \text{arg: girl apple} \\ \text{prn: 7} \end{array} \right]$	$\left[\begin{array}{l} \text{noun: apple} \\ \text{sem: indef sg} \\ \text{fnc: eat} \\ \text{mdr:} \\ \text{prn: 7} \end{array} \right]$	

	6. PNC	{PNC-START}	
<i>rule level</i>	$\left[\begin{array}{l} \text{noun: } \beta \\ \text{fnc: } \alpha \\ \text{prn: K} \end{array} \right]$	$\left[\begin{array}{l} \text{verb: } \alpha \\ \text{cat: PNC} \\ \text{arg: X } \beta \\ \text{prn: K} \end{array} \right]$	$\begin{array}{c} \cdot \\ \uparrow \\ \Rightarrow \text{lex(PNC)} \end{array}$
<i>content level</i>	$\left[\begin{array}{l} \text{noun: apple} \\ \text{sem: indef sg} \\ \text{fnc: eat} \\ \text{mdr:} \\ \text{prn: 7} \end{array} \right]$	$\left[\begin{array}{l} \text{verb: eat} \\ \text{cat: decl} \\ \text{sem: past} \\ \text{arg: girl apple} \\ \text{prn: 7} \end{array} \right]$	

7.4.4 Representing an extrapositional coordination

(i) *semantic relations graph (SRG)*

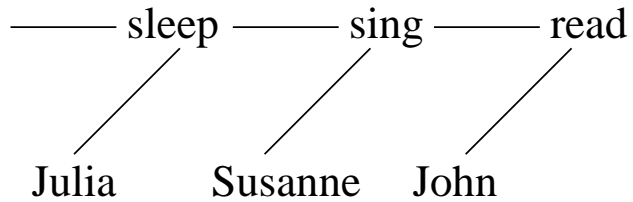

(iii) *numbered arcs graph (NAG)*

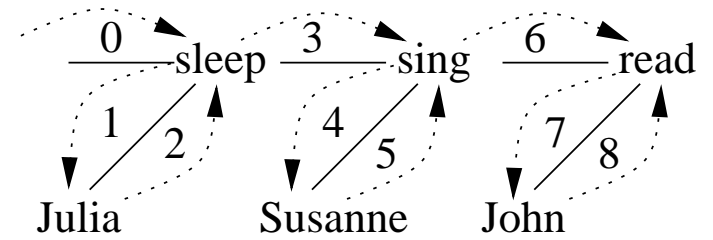

(ii) *signature*

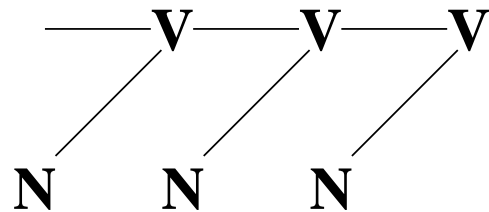

(iv) *surface realization*

0-1 2 3-4 5 6-7 8
 Julia slept_ Susanne sang_ John read_

7.4.5 Russian word order based on alternative traversals

(i) SRG

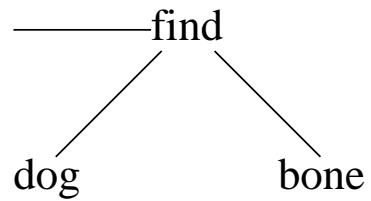

(ii) signature

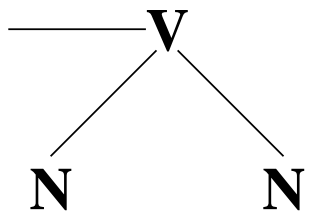

(iii) NAGs

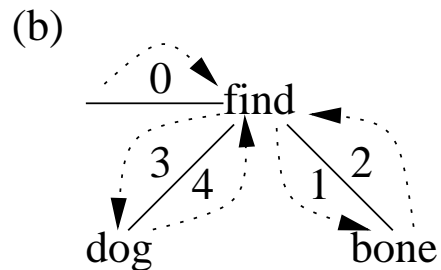
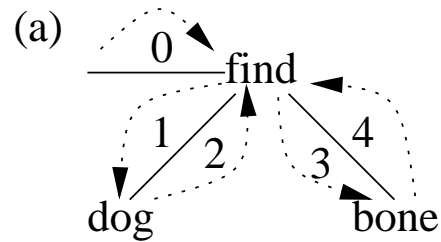

(iv) surface realizations

- (1) 0-1 2 3 4
dog find bone .
- (2) 0-1 2-3 4
dog bone find__ .
- (3) 0 1 2-3 4
find dog bone .
- (4) 0 1 2-3 4
find bone dog .
- (5) 0-1 2 3 4
bone find dog .
- (6) 0-1 2-3 4
bone dog find__ .

7.5.2 Proplet representation of That Fido barked surprised Mary.

[noun: Fido cat: nm sem: sg fnc: bark mdr: prn: 27]	[verb: bark cat: v sem: past arg: Fido fnc: (surprise 28) prn: 27]	[verb: surprise cat: decl sem: past arg: (bark 27) Mary mdr: prn: 28]	[noun: Mary cat: nm sem: sg fnc: surprise mdr: prn: 28]
--	---	--	--

7.5.3 Three-place verb with prepositional phrase as object: Julia put the flowers in a vase.

(i) semantic relations graph (SRG)

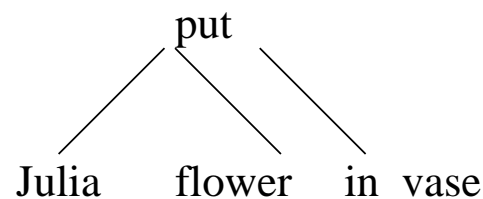

(ii) numbered arcs graph (NAG)

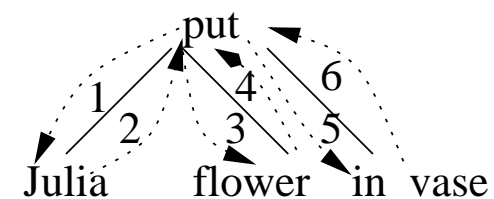

(ii) signature

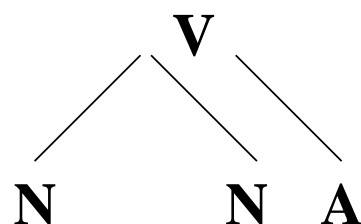

(iv) surface realization

1	2	3	4-5	6
Julia	put	the_flowers	in_a_vase	.

7.5.4 Opaque intrapositional object, content of 7.5.3

[noun: Julia cat: nm sem: sg fnc: put mdr: prn: 26]	[verb: put cat: decl sem: past arg: Julia flower in_vase mdr: prn: 26]	[noun: flower cat: sn sem: def pl fnc: put mdr: prn: 26]	[adj: in_vase cat: adv snp sem: indef sg fnc: put mdr: prn: 26]
--	---	---	--

7.5.5 Hear mode derivation of Julia is a doctor.

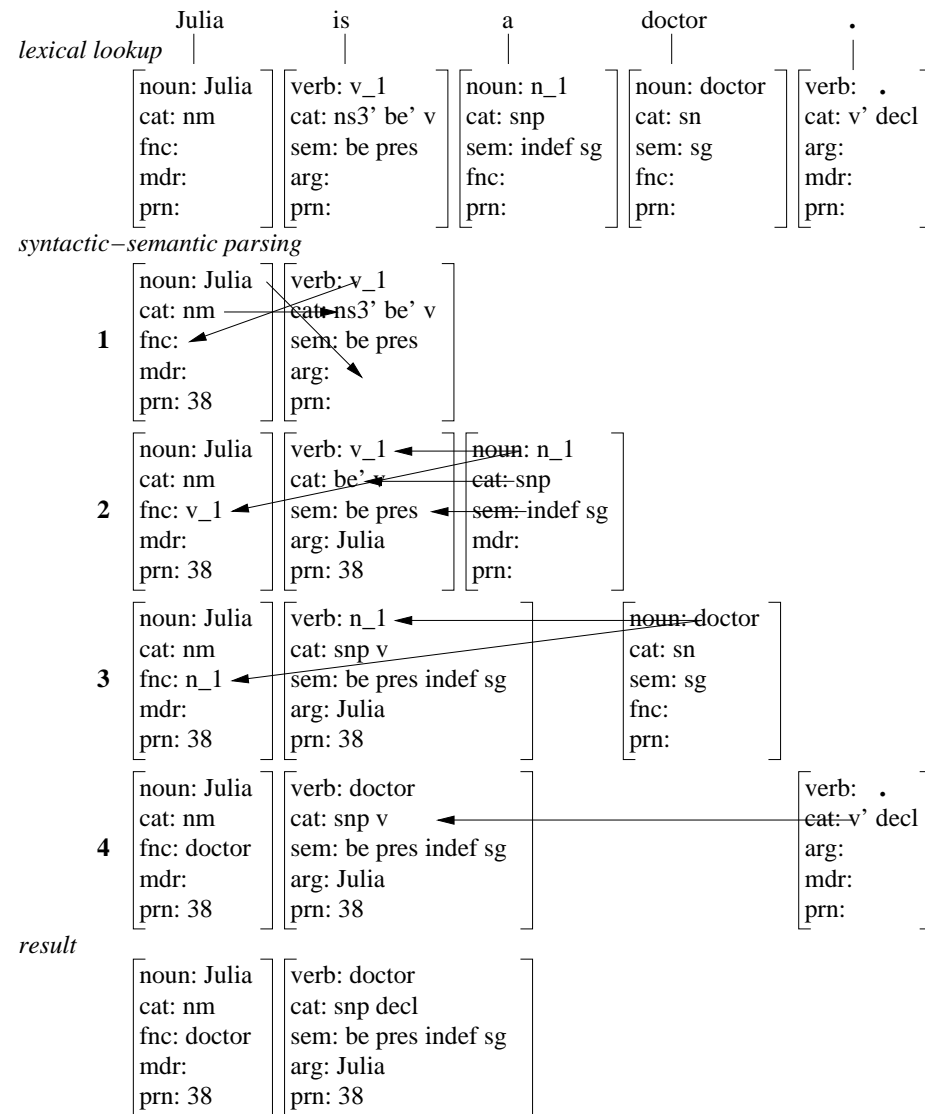

7.5.6 DBS graph analysis of Julia is a doctor.

(i) *semantic relations graph (SRG)*

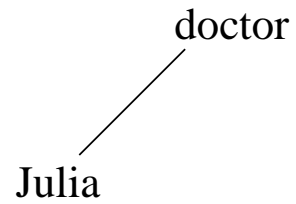

(ii) *signature*

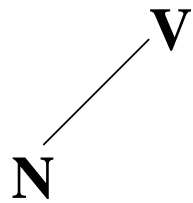

(iii) *numbered arcs graph (NAG)*

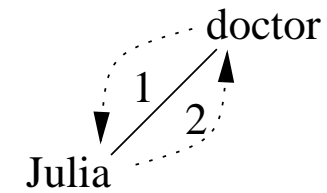

(iv) *surface realization*

1 2
Julia is_a_doctor_ .

7.6 Possible and Actual Semantic Relations of Structure

7.6.1 Transparent and opaque relations beginning with N

- 1 N/N ?
- 2 N/V subject/verb (transparent)
- 3 N/A ?
- 4 N\N ?
- 5 N\V object\verb (transparent)
- 6 N\A ?
- 7 N|N ?
- 8 N|V ?
- 9 N|A ?
- 10 N–N noun–noun conjunction (transparent)
- 11 N–V ?
- 12 N–A ?

7.6.2 Transparent and opaque relations beginning with V

- 1 V/N ?
- 2 V/V infinitive_subject/verb (opaque)
- 3 V/A ?
- 4 V\N ?
- 5 V\V infinitive_object\verb (opaque)
- 6 V\A ?
- 7 V|N progressive_verb|noun, infinitive|noun (opaque)
- 8 V|V ?
- 9 V|A ?
- 10 V–N ?
- 11 V–V verb–verb (transparent)
- 12 V–A ?

7.6.3 Transparent and opaque relations beginning with A

- 1 A/N ?
- 2 A/V ?
- 3 A/A ?
- 4 A\N ?
- 5 A\V prepositional_object\verb (opaque)
- 6 A\A ?
- 7 A|N adj|noun (transparent)
- 8 A|V adj|verb (transparent)
- 9 A|A ?
- 10 A–N ?
- 11 A–V ?
- 12 A–A adj-adj coordination (transparent)

7.6.4 Transparent vs. opaque intrapositional relations

transparent intrapositional relations

1. N/V (subject/verb)
2. N\ V (object\verb)
3. A|N (adj|noun)
4. A|V (adj|verb)
5. N–N (noun–noun)
6. V–V (verb–verb)
7. A–A (add–adj)

opaque intrapositional relations

8. V/V (infinitive_subject/verb)
9. V\ V (infinitive_object\verb)
10. V|N (progressive_verb|noun, infinitive|noun)
11. A\ V (prepositional_object\verb)

7.6.5 Extrapositional relations of English

- 12 $V/_x V$ sentential_subject/ $_x$ verb (opaque)
- 13 $V \backslash_x V$ sentential_object \backslash_x verb (opaque)
- 14 $V|_x N$ sentential_adnominal $|_x$ noun, a.k.a. relative clause (opaque)
- 15 $V|_x V$ sentential_adverbial $|_x$ verb (opaque)
- 16 $V -_x V$ extrapositional $-_x$ coordination (transparent)

7.6.6 Content analysis corresponding to a 20-word sentence

(i) semantic relations graph (SRG)

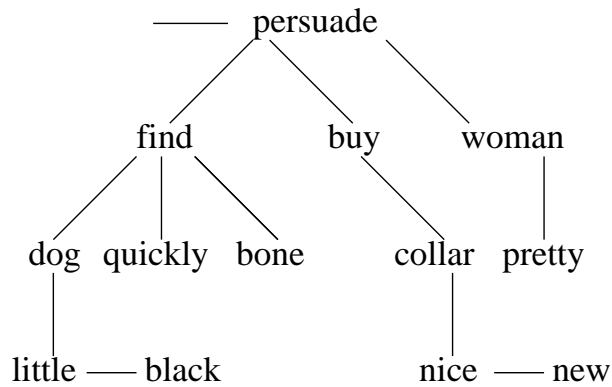

(ii) signature

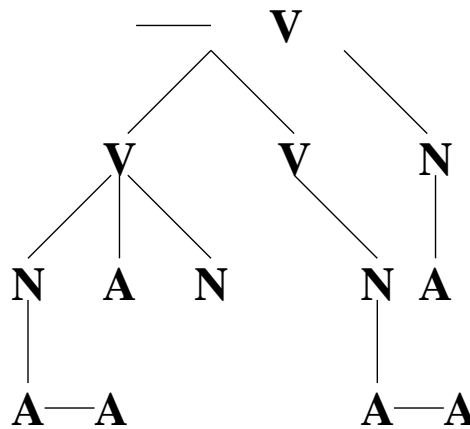

(iii) numbered arcs graph (NAG)

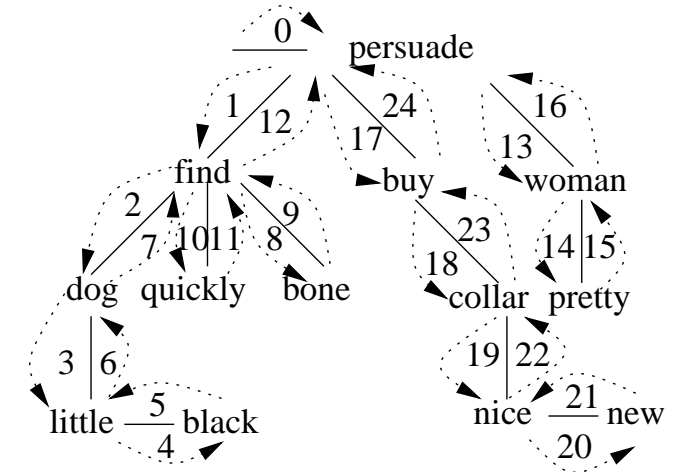

(iv) surface realization

1	2	3	4	5-6	7	8	9-10	11-12
That	the	little	black	dog	found	the_bone	quickly	persuaded
13	14	15	16-17	18	19	20	21-22	23-24
the	pretty	woman	to_buy	a	nice	new	collar	.

8. Simultaneous Amalgamation

8.1 Intuitive Outline of LA-Content

8.1.1 Simultaneous amalgamation of content corresponding to English The little black dog found the bone quickly.

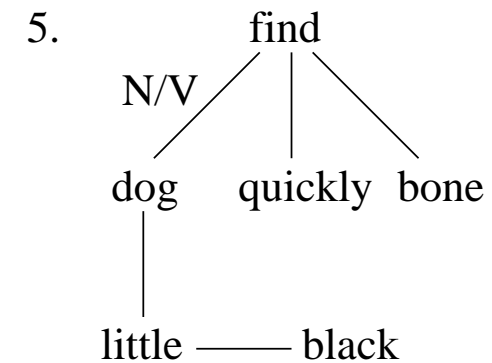
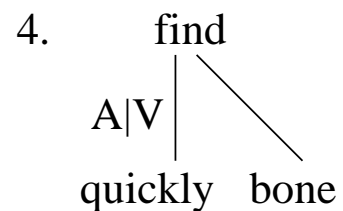
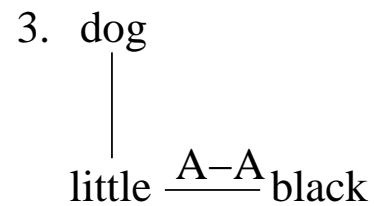
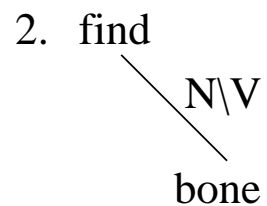
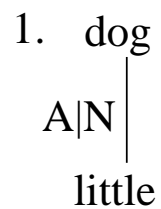

8.1.2 Steps of an elementary amalgamation

1. Raw data provided by the agent's visual, auditory, and other perception components are classified by concept types provided by the agent's memory, based on the principle of best match – as in a Rorschach test.
2. The instantiated concept tokens are embedded into N, V, or A proplet shells (6.6.1, 6.6.6).
3. Selected pairs of nodes resulting from 2 are connected such that they form one of the 16 elementary signatures defined in 7.6.4 and 7.6.5.

8.1.3 Unambiguous and ambiguous input to signatures

Unambiguous match for {A, N}

3. A|N (e.g., little|dog)

Unambiguous match for {N, N}

5. N—N (e.g., man—woman)

Unambiguous match for {A, A}

7. A—A (e.g., little—black)

Ambiguous match for {A, V}

4. A|V (e.g., beautifully|sing)

11. A\V (e.g., in_vase\put)

Ambiguous match for {N, V}

1. N/V (e.g., John/gave)
2. N\V (e.g., Mary\gave)
10. V|N (e.g., burning|fire, to_help|desire)
14. V|_xN (e.g., who_loves|Mary)

Ambiguous match for {V, V}

6. V–V (e.g., walk–talk)
8. V/V (e.g., to_err/is)
9. V\V (e.g., to_read\try)
12. V/_xV (e.g., that_bark/surprise)
13. V_xV (e.g., that_bark\hear)
15. V|_xV (e.g., when_bark|smile)
16. V–_xV (e.g., sleep–read)

8.1.4 Interaction of five cognitive procedures

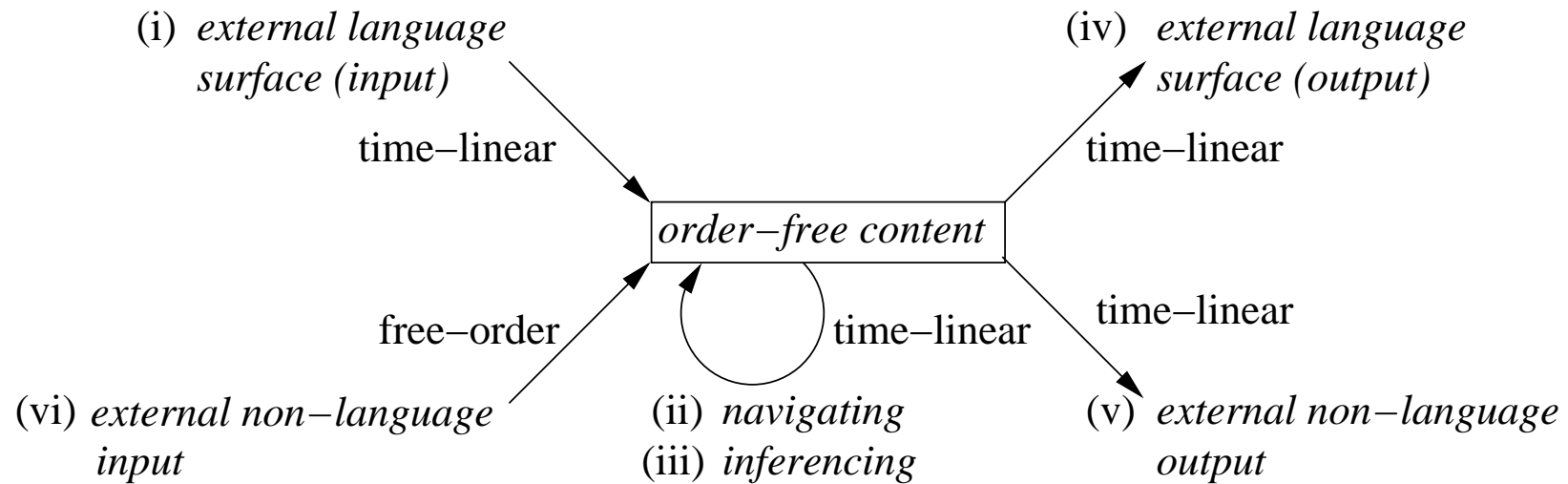

8.2 Formal Definition of LA-Content

8.2.1 Definition of LA-content

$ST_S =_{def} \{([RA: \alpha] \{rules\ 1-16\})\}$

$$1. \ N/V: \begin{bmatrix} \text{noun: } \alpha \\ \text{fnc:} \\ \text{prn:} \end{bmatrix} \begin{bmatrix} \text{verb: } \beta \\ \text{arg:} \\ \text{prn:} \end{bmatrix} \Rightarrow \begin{bmatrix} \text{noun: } \alpha \\ \text{fnc: } \beta \\ \text{prn: K} \end{bmatrix} \begin{bmatrix} \text{verb: } \beta \\ \text{arg: } \alpha \\ \text{prn: K} \end{bmatrix} \{rules\ 2-6\ \text{and}\ 8-16\}$$

$$2. \ N \setminus V: \begin{bmatrix} \text{noun: } \alpha \\ \text{fnc:} \\ \text{prn:} \end{bmatrix} \begin{bmatrix} \text{verb: } \beta \\ \text{arg: X} \\ \text{prn:} \end{bmatrix} \Rightarrow \begin{bmatrix} \text{noun: } \alpha \\ \text{fnc: } \beta \\ \text{prn: K} \end{bmatrix} \begin{bmatrix} \text{verb: } \beta \\ \text{arg: X } \alpha \\ \text{prn: K} \end{bmatrix} \{rules\ 1-6,\ \text{and}\ 8-16\}$$

$$3. \ A|N: \begin{bmatrix} \text{adj: } \alpha \\ \text{mdd:} \\ \text{prn:} \end{bmatrix} \begin{bmatrix} \text{noun: } \beta \\ \text{mdr:} \\ \text{prn:} \end{bmatrix} \Rightarrow \begin{bmatrix} \text{adj: } \alpha \\ \text{mdd: } \beta \\ \text{prn: K} \end{bmatrix} \begin{bmatrix} \text{noun: } \beta \\ \text{mdr: } \alpha \\ \text{prn: K} \end{bmatrix} \{rules\ 1-2,\ 4-7,\ 10-11,\ \text{and}\ 14\}$$

$$4. \ A|V: \begin{bmatrix} \text{adj: } \alpha \\ \text{mdd:} \\ \text{prn:} \end{bmatrix} \begin{bmatrix} \text{verb: } \beta \\ \text{mdr:} \\ \text{prn:} \end{bmatrix} \Rightarrow \begin{bmatrix} \text{adj: } \alpha \\ \text{mdd: } \beta \\ \text{prn: K} \end{bmatrix} \begin{bmatrix} \text{verb: } \beta \\ \text{mdr: } \alpha \\ \text{prn: K} \end{bmatrix} \{rules\ 1-4\ \text{and}\ 6-16\}$$

$$5. \text{ N-N: } \begin{bmatrix} \text{noun: } \alpha \\ \text{nc:} \\ \text{prn:} \end{bmatrix} \begin{bmatrix} \text{noun: } \beta \\ \text{pc:} \\ \text{prn:} \end{bmatrix} \Rightarrow \begin{bmatrix} \text{noun: } \alpha \\ \text{nc: } \beta \\ \text{prn: K} \end{bmatrix} \begin{bmatrix} \text{noun: } \beta \\ \text{pc: } \alpha \\ \text{prn: K} \end{bmatrix} \{\text{rules 1-3, 5, 10, 14}\}$$

$$6. \text{ V-V: } \begin{bmatrix} \text{verb: } \alpha \\ \text{nc:} \\ \text{prn:} \end{bmatrix} \begin{bmatrix} \text{verb: } \beta \\ \text{pc:} \\ \text{prn:} \end{bmatrix} \Rightarrow \begin{bmatrix} \text{verb: } \alpha \\ \text{nc: } \beta \\ \text{prn: K} \end{bmatrix} \begin{bmatrix} \text{verb: } \beta \\ \text{pc: } \alpha \\ \text{prn: K} \end{bmatrix} \{\text{rules 1-2, 4, 6, 8-16}\}$$

$$7. \text{ A-A: } \begin{bmatrix} \text{adj: } \alpha \\ \text{nc:} \\ \text{prn:} \end{bmatrix} \begin{bmatrix} \text{adj: } \beta \\ \text{pc:} \\ \text{prn:} \end{bmatrix} \Rightarrow \begin{bmatrix} \text{adj: } \alpha \\ \text{nc: } \beta \\ \text{prn: K} \end{bmatrix} \begin{bmatrix} \text{adj: } \beta \\ \text{pc: } \alpha \\ \text{prn: K} \end{bmatrix} \{\text{3-4, 7, 11}\}$$

$$8. \text{ V/V: } \begin{bmatrix} \text{verb: } \alpha \\ \text{arg:} \\ \text{prn:} \end{bmatrix} \begin{bmatrix} \text{verb: } \beta \\ \text{arg:} \\ \text{prn:} \end{bmatrix} \Rightarrow \begin{bmatrix} \text{verb: } \alpha \\ \text{arg:} \\ \text{fnc: } \beta \\ \text{prn: K} \end{bmatrix} \begin{bmatrix} \text{verb: } \beta \\ \text{arg: } \alpha \\ \text{prn: K} \end{bmatrix} \{\text{rules 2, 4, 6, 9-16}\}$$

$$9. \text{ V}\backslash\text{V: } \begin{bmatrix} \text{verb: } \alpha \\ \text{arg:} \\ \text{prn:} \end{bmatrix} \begin{bmatrix} \text{verb: } \beta \\ \text{arg: X} \\ \text{prn:} \end{bmatrix} \Rightarrow \begin{bmatrix} \text{verb: } \alpha \\ \text{arg:} \\ \text{fnc: } \beta \\ \text{prn: K} \end{bmatrix} \begin{bmatrix} \text{verb: } \beta \\ \text{arg: X } \alpha \\ \text{prn: K} \end{bmatrix} \{\text{rules 1-2, 4, 6, 8-16}\}$$

10. $V|N$: $\begin{bmatrix} \text{verb: } \alpha \\ \text{arg:} \\ \text{prn:} \end{bmatrix} \begin{bmatrix} \text{noun: } \beta \\ \text{mdr:} \\ \text{prn:} \end{bmatrix} \Rightarrow \begin{bmatrix} \text{verb: } \alpha \\ \text{mdd: } \beta \\ \text{prn: } k \end{bmatrix} \begin{bmatrix} \text{noun: } \beta \\ \text{mdr: } \alpha \\ \text{prn: } K \end{bmatrix} \{\text{rules 1–6 and 8–16}\}$
11. $A \setminus V$: $\begin{bmatrix} \text{adj: } \alpha \\ \text{mdd:} \\ \text{prn:} \end{bmatrix} \begin{bmatrix} \text{verb: } \beta \\ \text{arg: } X \\ \text{prn:} \end{bmatrix} \Rightarrow \begin{bmatrix} \text{adj: } \alpha \\ \text{fnc: } \beta \\ \text{prn: } K \end{bmatrix} \begin{bmatrix} \text{verb: } \beta \\ \text{arg: } X \alpha \\ \text{prn: } K \end{bmatrix} \{\text{rules 1–4 and 6–16}\}$
12. V/xV : $\begin{bmatrix} \text{verb: } \alpha \\ \text{arg:} \\ \text{prn:} \end{bmatrix} \begin{bmatrix} \text{verb: } \beta \\ \text{arg:} \\ \text{prn:} \end{bmatrix} \Rightarrow \begin{bmatrix} \text{verb: } \alpha \\ \text{arg:} \\ \text{fnc: } (\beta K+1) \\ \text{prn: } K \end{bmatrix} \begin{bmatrix} \text{verb: } \beta \\ \text{arg: } (\alpha K) \\ \text{prn: } K+1 \end{bmatrix} \{\text{rules 1–2, 4, 6, 8–11, 13–16}\}$
13. $V \setminus_x V$: $\begin{bmatrix} \text{verb: } \alpha \\ \text{arg:} \\ \text{prn:} \end{bmatrix} \begin{bmatrix} \text{verb: } \beta \\ \text{arg:} \\ \text{prn:} \end{bmatrix} \Rightarrow \begin{bmatrix} \text{verb: } \alpha \\ \text{arg:} \\ \text{fnc: } (\beta K+1) \\ \text{prn: } K \end{bmatrix} \begin{bmatrix} \text{verb: } \beta \\ \text{arg: } X (\alpha K) \\ \text{prn: } K+1 \end{bmatrix} \{\text{rules 1–2, 4, 6, 8–16}\}$
14. $V|xN$: $\begin{bmatrix} \text{verb: } \alpha \\ \text{arg:} \\ \text{prn:} \end{bmatrix} \begin{bmatrix} \text{noun: } \beta \\ \text{mdr:} \\ \text{prn:} \end{bmatrix} \Rightarrow \begin{bmatrix} \text{verb: } \alpha \\ \text{arg:} \\ \text{mdd: } (\beta K) \\ \text{prn: } K+1 \end{bmatrix} \begin{bmatrix} \text{noun: } \beta \\ \text{mdr: } (\alpha K+1) \\ \text{prn: } K \end{bmatrix} \{\text{rules 1–6 and 8–16}\}$

$$15. \quad V|_x V: \begin{bmatrix} \text{verb: } \alpha \\ \text{mdr:} \\ \text{prn:} \end{bmatrix} \begin{bmatrix} \text{verb: } \beta \\ \text{mdr: } X \\ \text{prn:} \end{bmatrix} \Rightarrow \begin{bmatrix} \text{verb: } \alpha \\ \text{mdr:} \\ \text{mdd: } (\beta \text{ K}+1) \\ \text{prn: } K \end{bmatrix} \begin{bmatrix} \text{verb: } \beta \\ \text{mdr: } X (\alpha \text{ K}) \\ \text{prn: } K+1 \end{bmatrix} \{\text{rules 1-2, 4, 6, 8-16}\}$$

$$16. \quad V-x V: \begin{bmatrix} \text{verb: } \alpha \\ \text{nc:} \\ \text{prn:} \end{bmatrix} \begin{bmatrix} \text{verb: } \beta \\ \text{pc:} \\ \text{prn:} \end{bmatrix} \Rightarrow \begin{bmatrix} \text{verb: } \alpha \\ \text{nc: } (\beta \text{ K}+1) \\ \text{prn: } K \end{bmatrix} \begin{bmatrix} \text{verb: } \beta \\ \text{pc: } (\alpha \text{ K}) \\ \text{prn: } K+1 \end{bmatrix} \{\text{rules 1-2, 4, 6, 8-16}\}$$

$$ST_F =_{def} \{([\text{cat: } X] \text{ rp}_{rules1--16})\}$$

8.3 Linear Complexity of LA-Content

8.3.1 Recursive structures in natural language

1. *Intrapropositional coordination*

Examples: (i) The man, the woman, the child, ..., and the cat (noun coordination); cf. rule 5 (N–N) in 8.2.1. (ii) Peter bought, peeled, cooked, cut, spiced, served, ..., and ate the potatoes (verb coordination); cf. rule 6 (V–V). (iii) The fuzzy clever little black hungry ... dog (adnominal coordination); cf. rule 7 (A–A).

2. *Extrapropositional coordination*

Example: Julia slept. Susanne sang. John read.; cf. rule 16 ($V -_x V$) in 8.2.1, 3.2.5 for a proplet representation, and 7.4.4 for a DBS analysis.

3. *Iterated object sentences*

Example: John said that Bill believes that Mary suspects that Suzy knows that Lucy loves Tom; cf. rule 13 ($V \setminus_x V$) in 8.2.1, and 9.4.1 for a DBS analysis. Related are the constructions of *unbounded* or *long distance dependency*, such as *Who did John say that Bill believes that Mary suspects that Suzy knows that Lucy loves?*, which are analyzed in 9.4.2. Iterated object sentences may also serve as a subject sentence, as in *That Bill believes that Mary suspects that Suzy knows that Lucy loves Tom surprised John.*

4. *Iterated relative clauses*

Example: The man who loves the woman who feeds the child who has a cat is sleeping; cf. rule 14 ($V|_xN$) in 8.2.1, and 9.3.3 for a DBS analysis.

5. *Gapping constructions*

Examples: (i) Bob ate an apple, walked the dog, read the paper, had a beer, called Mary, ..., and took a nap. (subject gapping); cf. rule 1 (N/V) in 8.2.1 and 9.5.5 for a DBS analysis. (ii) Bob ate an apple, Jim a pear, Bill a peach, Suzy some grapes, ..., and Tom a tomato. (verb gapping); cf. rules 1 (N/V) and 2 ($N \setminus V$), and 9.5.3 for a DBS analysis. (iii) Bob bought, Jim peeled, Bill sliced, Peter served, and Suzy ate the peach (object gapping); cf. rule 2 ($N \setminus V$), and 9.6.3 for a DBS analysis. (iv) Bob ate the red, the green, and the blue berries. (noun gapping); cf. rule 3 ($A|N$), and 9.6.5 for a DBS analysis.

6. *Iterated prepositional phrases*

Example: Julia ate the apple on the table behind the tree in the garden ...; cf. rule 3 ($A|N$) in 8.2.1, and 7.2.4 for a partial DBS analysis.

8.4 Infinitive Content Constructions

8.4.1 Hear mode derivation of John tried to read a book

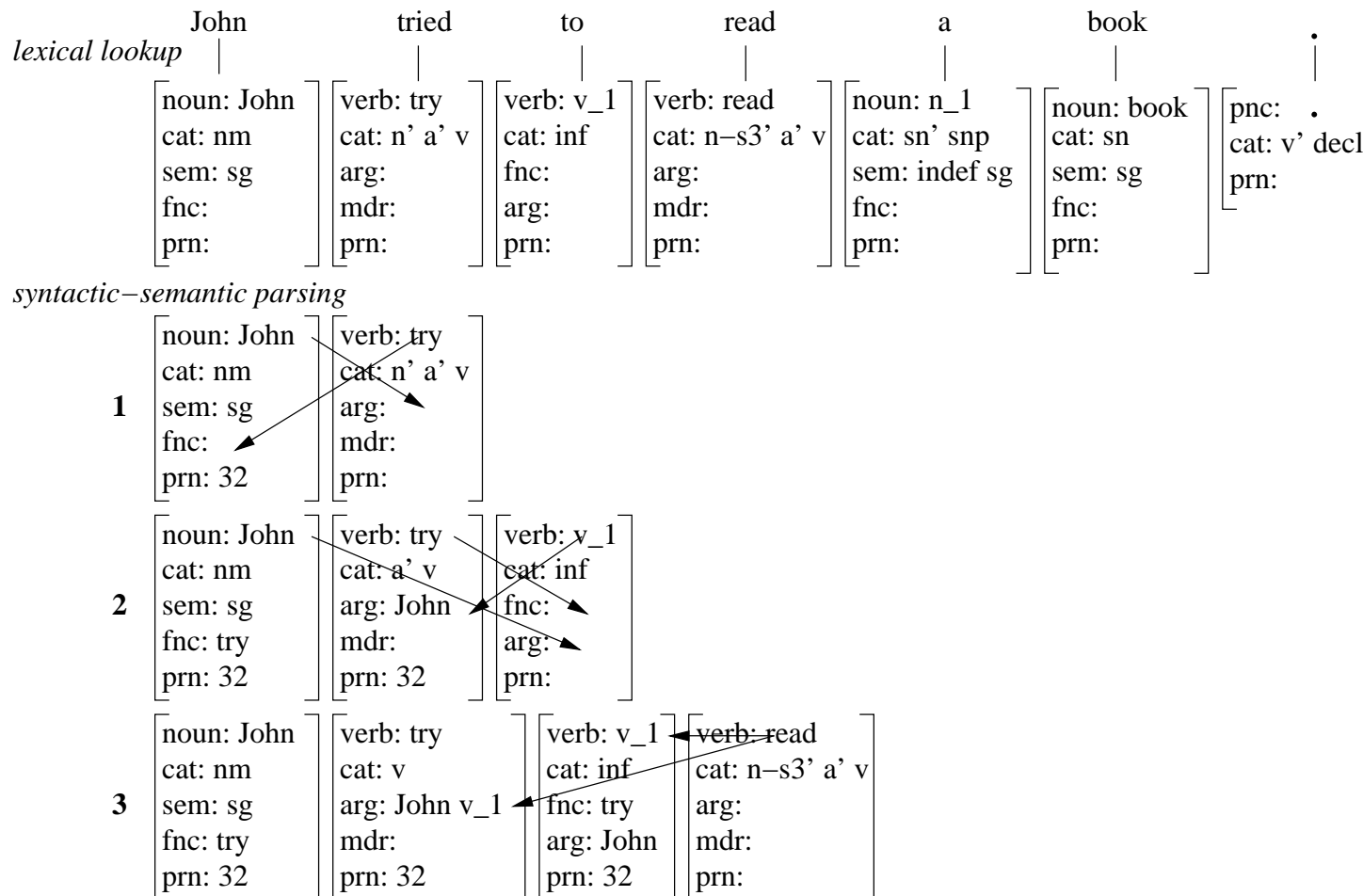

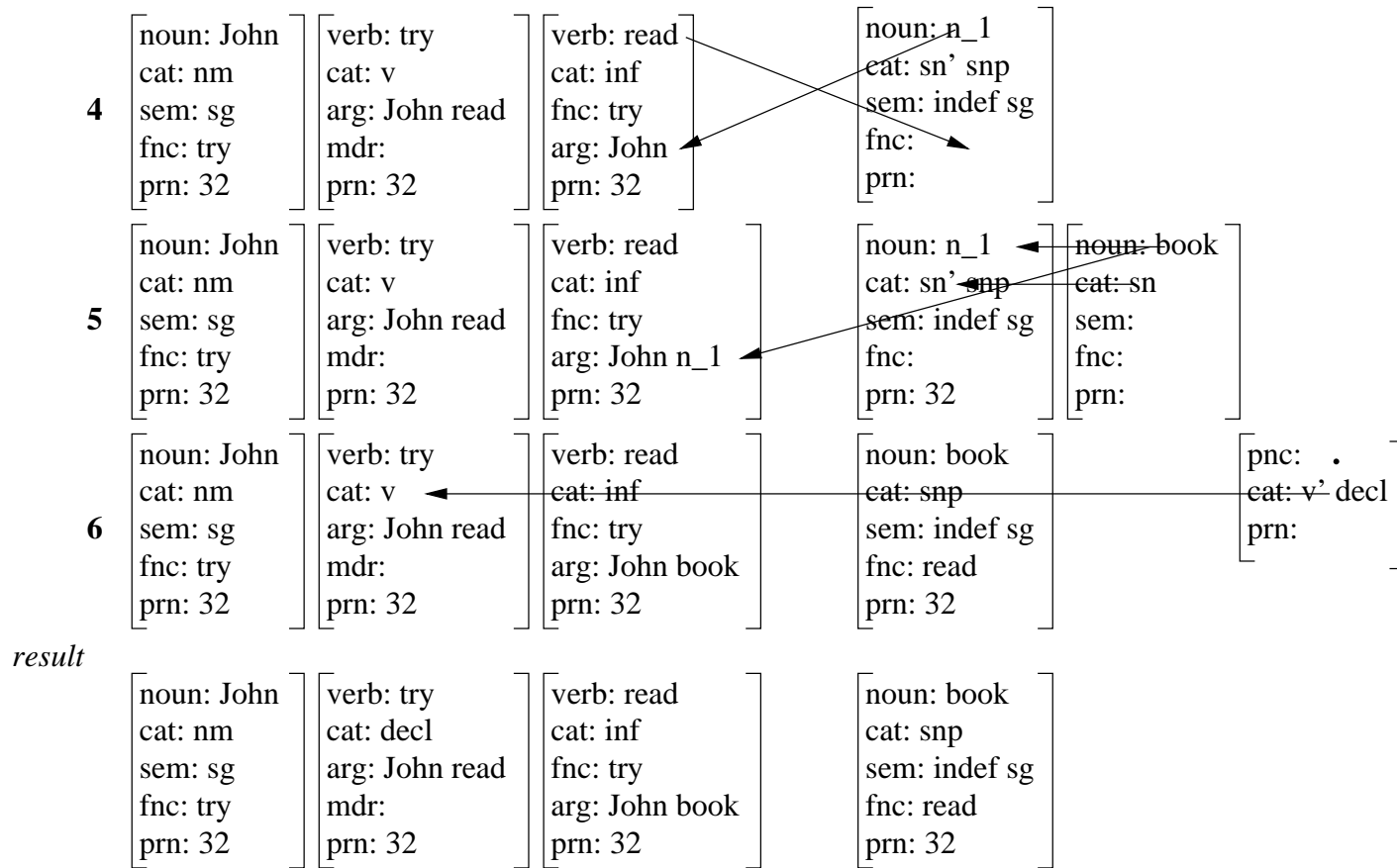

8.4.2 Content representation of an infinitive construction

$\left[\begin{array}{l} \text{noun: John} \\ \text{cat: nm} \\ \text{sem: sg} \\ \text{fnc: try} \\ \text{prn: 32} \end{array} \right]$	$\left[\begin{array}{l} \text{verb: try} \\ \text{cat: decl} \\ \text{arg: John read} \\ \text{mdr:} \\ \text{prn: 32} \end{array} \right]$	$\left[\begin{array}{l} \text{verb: read} \\ \text{cat: inf} \\ \text{fnc: try} \\ \text{arg: John book} \\ \text{prn: 32} \end{array} \right]$	$\left[\begin{array}{l} \text{noun: book} \\ \text{cat: snp} \\ \text{sem: indef sg} \\ \text{fnc: read} \\ \text{prn: 32} \end{array} \right]$
--	--	--	--

8.4.3 Schema characterizing an elementary $V \setminus V$ signature

(9) verb \ verb

$\left[\begin{array}{l} \text{verb: } \beta \\ \text{fnc: } \alpha \\ \text{arg: } \gamma X \end{array} \right]$	$\left[\begin{array}{l} \text{verb: } \alpha \\ \text{arg: } \gamma \beta Y \end{array} \right]$
---	---

to read *try*

(examples of matching proplets for illustration only)

8.4.4 DBS graph analysis of a content corresponding to John tried to read a book

(i) semantic relations graph (SRG)

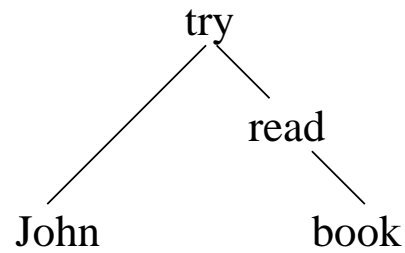

(iii) numbered arcs graph (NAG)

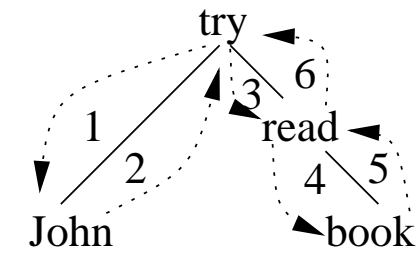

(ii) signature

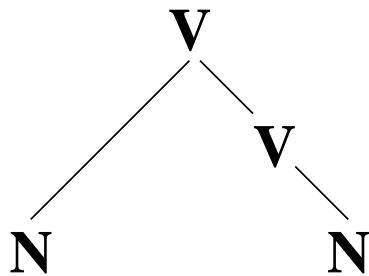

(iv) surface realization

1	2	3	4	5-6
John	tried	to__read	a__book	.

8.5 Selectional Constellations of Elementary Signatures

8.5.1 Try class infinitive constructions

1. nominal object: John tried a cookie.
2. one-place infinitive object: John tried to sleep.
3. two-place inf. object: John tried to read a book.
4. three-place inf. object: John tried to give Mary a kiss.
5. inf. with prepositional object: Julia tried to put the flower in a vase.
6. inf. with object sentence recursion: Julia tried to say that Bill believes that Mary suspects that Susy knows that Lucy loves Tom. ...

8.5.2 Definition of try class infinitives

verb \ verb

$$\begin{bmatrix} \text{verb: } \beta \\ \text{fnc: } \alpha \\ \text{arg: } \gamma \text{ X} \end{bmatrix}$$
to read *try*

noun \ verb

$$\begin{bmatrix} \text{noun: } \beta \\ \text{fnc: } \alpha \end{bmatrix} \begin{bmatrix} \text{verb: } \alpha \\ \text{arg: } \gamma \beta \end{bmatrix}$$
cookie *try*

(examples of matching proplets, for illustration only)

where $\alpha \in \{\text{begin, can afford, choose, decide, expect, forget, learn, like, manage, need, offer, plan, prepare, refuse, start, try, want}\}$

Selectional constellations:

matrix verb α *subject* γ

begin 18 992 people 204, men 55, government 54, number 49, ...

can afford 1 841 ...

...

matrix verb α *subject* γ

begin 6 642 government 32, people 26, commission 24, ...

can afford 1 542 ...

...

infinitival object β

feel 528, be 492, take 371, ...

...

nominal object β

work 206, career 141, life 113, ...

...

8.5.3 Sorting nominal decide objects into a Corpus Word Bank

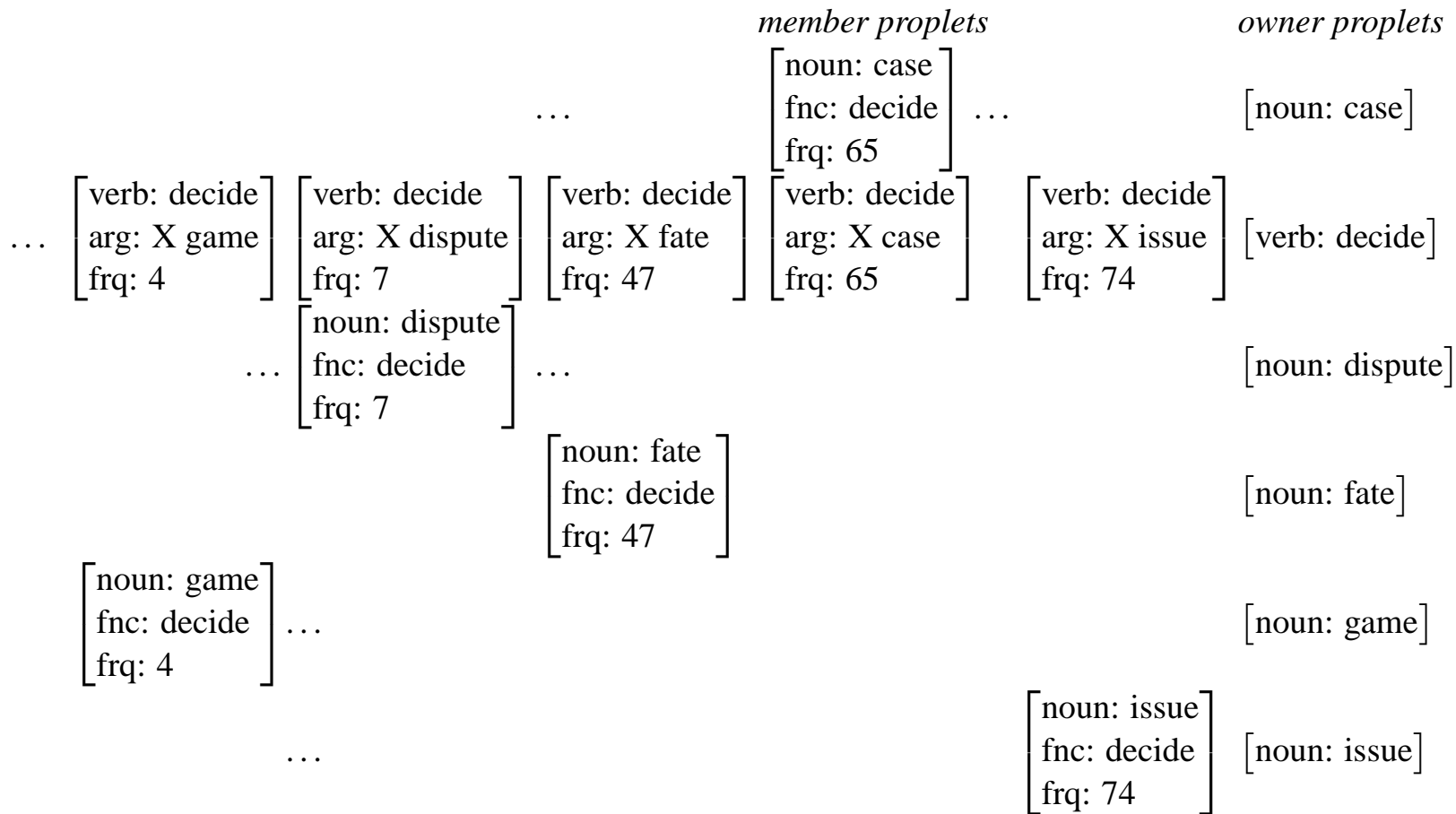

8.5.4 Formal query and answer 1

query

```
[verb: decide]
[arg: X case]
[frq: ?]
```

result

```
[verb: decide]
[arg: X case]
[frq: 65]
```

8.5.5 Formal query and answer 2

query

```
[noun: case]
[fnc: decide]
[frq: ?]
```

result

```
[noun: case]
[fnc: decide]
[frq: 65]
```

8.5.6 Formal query and answer 3

query

```
[verb: decide]
[arg: ?]
[frq: ?]
```

result

```
[noun: issue]
[fnc: decide]
[frq: 74]
```

```
[noun: case]
[fnc: decide]
[frq: 65]
```

```
[noun: fate]
[fnc: decide]
[frq: 57]
```

```
[noun: dispute]
[fnc: decide]
[frq: 7]
```

```
[noun: game]
[fnc: decide]
[frq: 4]
```

8.6 Appear, Promise, and Persuade Class Infinitives

8.6.1 Content structures corresponding to infinitives

1. Infinitive as subject: To err is human, to forgive divine.
2. Infinitive as object: John tried to read a book.
3. Infinitive as adnominal modifier: the desire to help
4. Bare infinitive: Peter saw the accident happen.

8.6.2 Bare infinitive: Peter saw the accident happen.

(i) *semantic relations graph (SRG)*

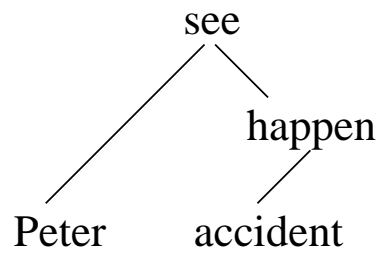

(iii) *numbered arcs graph (NAG)*

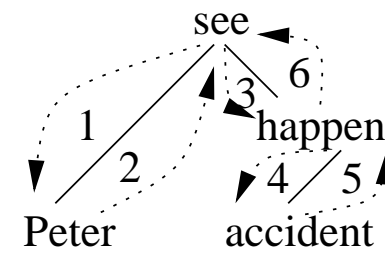

(ii) *signature*

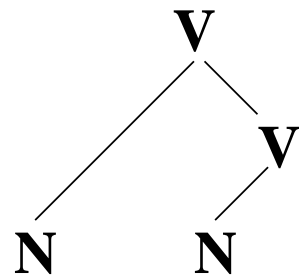

(iv) *surface realization*

1	2	3-4	5	6
Peter	saw	the__accident	happen	.

8.6.3 Appear class infinitive constructions

1. nominal object: *John appeared a cookie.
2. one-place infinitive object: John appeared to sleep.
... (as in 8.5.1)

8.6.4 Definition of appear class infinitives

verb \ verb

$$\begin{bmatrix} \text{verb: } \beta \\ \text{fnc: } \alpha \\ \text{arg: } \gamma \text{ X} \end{bmatrix} \begin{bmatrix} \text{verb: } \alpha \\ \text{arg: } \gamma \beta \end{bmatrix}$$

to sleep *appear* (examples of matching proplets for illustration only)

where $\alpha \in \{\text{agree, appear, be able, seem, tend}\}$

Selectional constellations:[omitted]

8.6.5 Promise class infinitive constructions

1. nominal object: John promised Mary a cookie.
2. one-place infinitive object: John promised Mary to sleep.
... (as in 8.5.1)

8.6.6 Definition of promise class infinitives

$$\begin{bmatrix} \text{noun: } \delta \\ \text{fnc: } \alpha \end{bmatrix} \begin{bmatrix} \text{verb: } \beta \\ \text{fnc: } \alpha \\ \text{arg: } \gamma \text{ X} \end{bmatrix} \begin{bmatrix} \text{verb: } \alpha \\ \text{arg: } \gamma \delta \beta \end{bmatrix} \quad \begin{bmatrix} \text{noun: } \delta \\ \text{fnc: } \alpha \end{bmatrix} \begin{bmatrix} \text{noun: } \beta \\ \text{fnc: } \alpha \end{bmatrix} \begin{bmatrix} \text{verb: } \alpha \\ \text{arg: } \gamma \delta \beta \end{bmatrix}$$

Mary to sleep promise Mary cookie promise (examples of matching proplets for illustration only)

where $\alpha \in \{\text{offer, promise, threaten}\}$

Selectional constellations:[omitted]

8.6.7 Persuade class infinitive constructions

1. nominal object: *John persuaded Mary a cookie.
2. one-place infinitive object: John persuaded Mary to sleep.
... (as in 8.5.1)

8.6.8 Definition of persuade class infinitives

$$\begin{bmatrix} \text{noun: } \delta \\ \text{fnc: } \alpha \end{bmatrix} \begin{bmatrix} \text{verb: } \beta \\ \text{fnc: } \alpha \\ \text{arg: } \delta \text{ X} \end{bmatrix} \begin{bmatrix} \text{verb: } \alpha \\ \text{arg: } \gamma \beta \delta \end{bmatrix}$$

Mary *to sleep* *persuade* (examples of matching contents, for illustration only)

where $\alpha \in \{\text{advise, allow, appoint, ask, beg, choose, convince, encourage, expect, forbid, force, invite, need, permit, persuade, select, teach, tell, urge, want, would like}\}$.

Selectional constellations:[omitted]

8.6.9 Object control in John persuaded Mary to read a book.

(i) semantic relations graph (SRG)

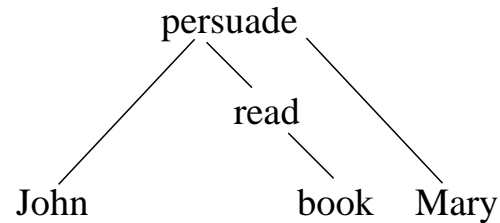

(ii) signature

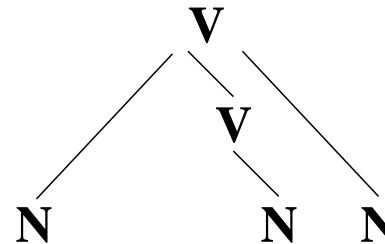

(iii) numbered arcs graph (NAG)

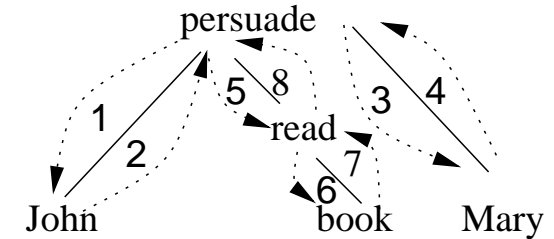

(iv) surface realization

1 2 3 4-5 6 7-8
 John persuaded Mary to__read a__book .

8.6.10 Corresponding proplet representation

[noun: John cat: nm sem: sg fnc: persuade prn: 36]	[verb: persuade cat: decl sem: past arg: John read Mary prn: 36]	[noun: Mary cat: nm sem: sg fnc: read prn: 36]	[verb: read cat: inf fnc: persuade arg: Mary book prn: 36]	[noun: book cat: snp sem: indef sg fnc: read prn: 36]
--	--	--	--	---

8.6.11 Subject control in John promised Mary to sleep.

(i) semantic relations graph (SRG)

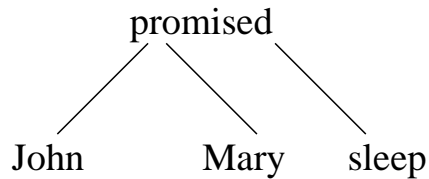

(iii) numbered arcs graph (NAG)

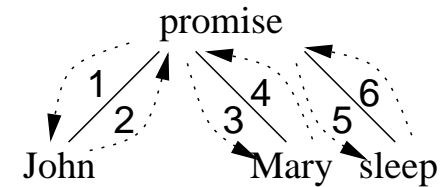

(ii) signature

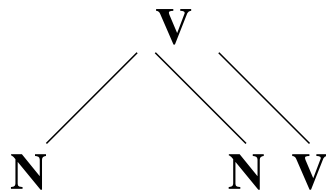

(iv) surface realization

1	2	3	4-5	6
John	promised	Mary	to__sleep	.

8.6.12 Proplet representation of John promised Mary to sleep.

noun: John cat: nm sem: sg fnc: promise prn: 35	verb: promise cat: decl sem: past arg: John Mary sleep prn: 35	noun: Mary cat: nm sem: sg fnc: promise prn: 35	verb: sleep cat: inf fnc: promise arg: John prn: 35
---	--	---	---

9. Graph Theory

9.1 Content Analysis as Undirected and Directed Graphs

9.1.1 The “complete” $n=4$ graph K_4

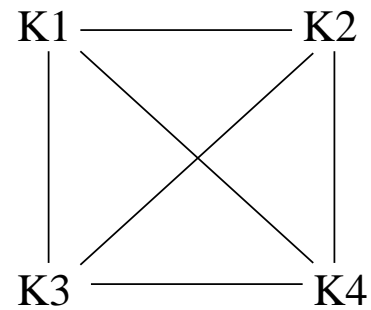

9.1.2 Same number of nodes but different degrees

The little girl ate an apple.

(i) *semantic relations graph (SRG)*

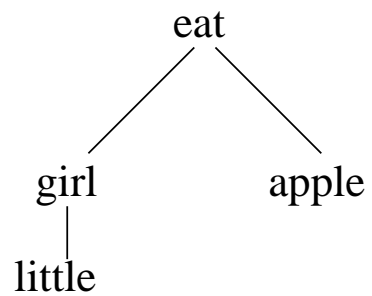

(ii) *signature*

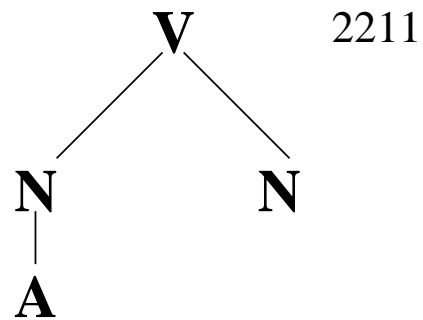

The man gave the child an apple

(i) *semantic relations graph (SRG)*

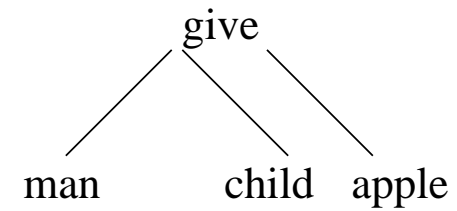

(ii) *signature*

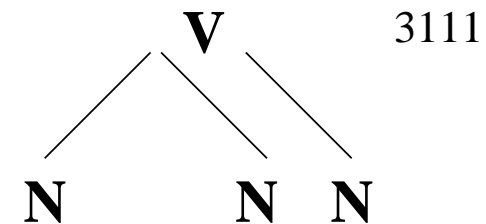

9.1.3 DBS graph analysis of a content: The dog found a bone.

(i) semantic relations graph (SRG)

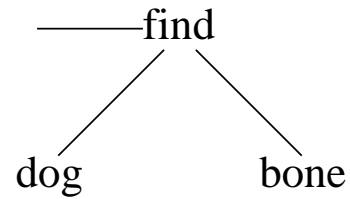

(iii) numbered arcs graph (NAG)

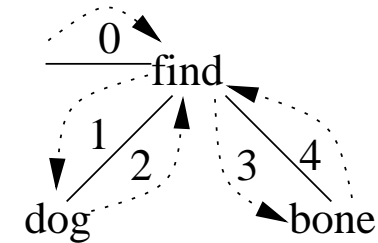

(ii) signature

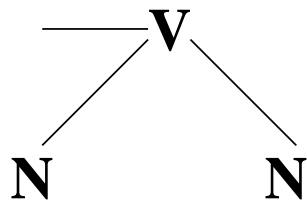

(iv) surface realization

1	2	3	4
The_dog	found	a_bone	.

9.1.4 Graph-theoretical constraints on wellformed NAGs

1. The signature must be *simple*, i.e., there must be no loops or multiple lines.
2. The NAG must be *symmetric*, i.e., for every arc connecting some nodes A and B, there must be an arc from B to A.
3. The traversal of arcs must be *continuous*, i.e., combining the traversal of arc x from A to B and of arc y from C to D is permitted only if $B = C$.
4. The numbering of arcs must be *exhaustive*, i.e., there must exist a navigation which traverses each arc.

9.1.5 Possible NAGs for an n=3 semantic relations graph

NAG 1

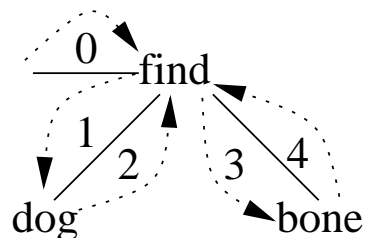

NAG 2

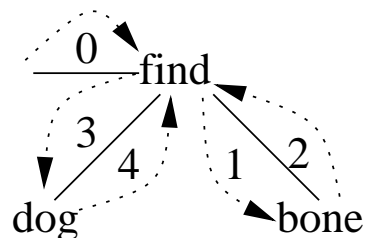

NAG 3

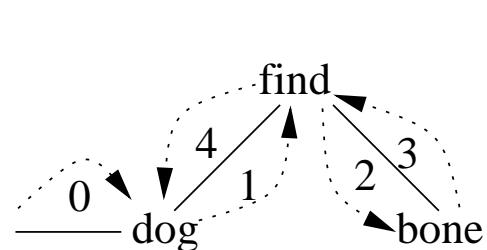

NAG 4

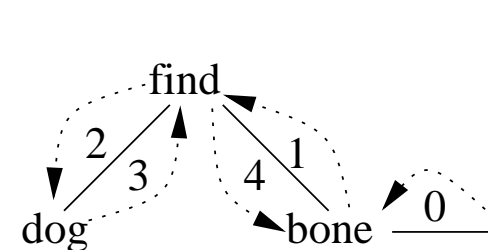

9.1.6 Linguistic constraints on wellformed NAGs

1. An intrapositional traversal must begin and end with the node which acts as the verb.
2. The initial verbal node must be entered either by arc 0 or by a corresponding arc from a preceding proposition (7.4.4).
3. The only lines permitted in a NAG are “/” (subject-verb), “\” (object-verb), “|” (modifier-modified), and “—” (conjunct-conjunct).
4. The only nodes permitted in a NAG based on a signature are N (noun), V (verb), and A (adjective).

9.1.7 Deriving English passive from content 9.1.3

(i) semantic relations graph (SRG)

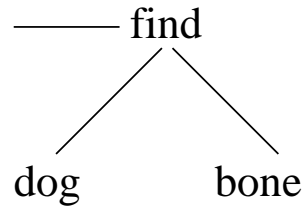

(iii) numbered arcs graph (NAG)

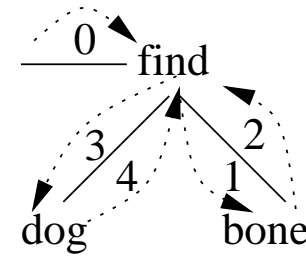

(iii) signature

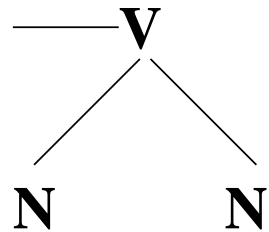

(iv) surface realization

1 2 3 4
 A_bone was_found by_the_dog .

9.2 Extrapositional Coordination

9.2.1 Extrapositional coordination of two propositions

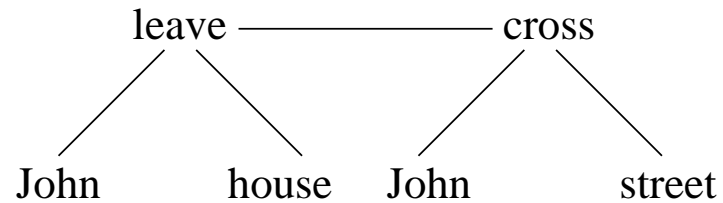

9.2.2 Bidirectional pointering in the proplet representation

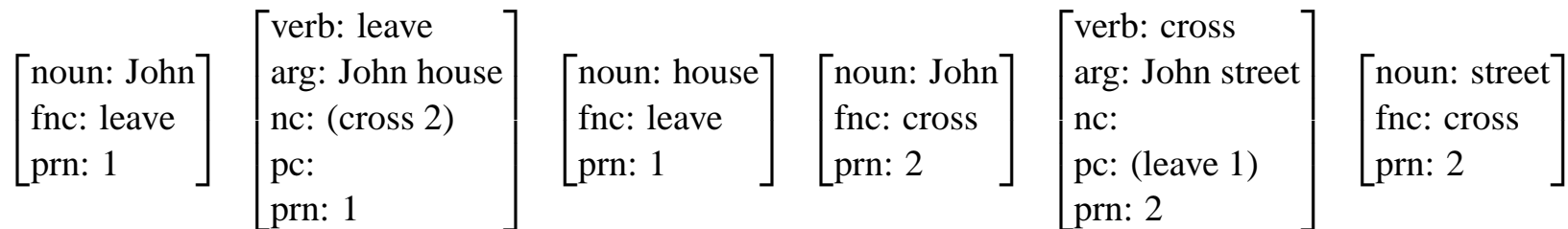

9.2.3 NAG for forward navigation through 9.2.1

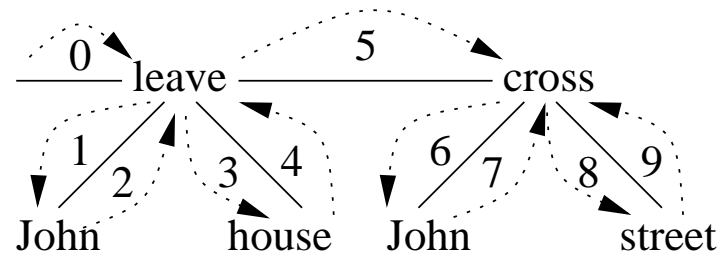

9.2.4 NAG for backward navigation through 9.2.1

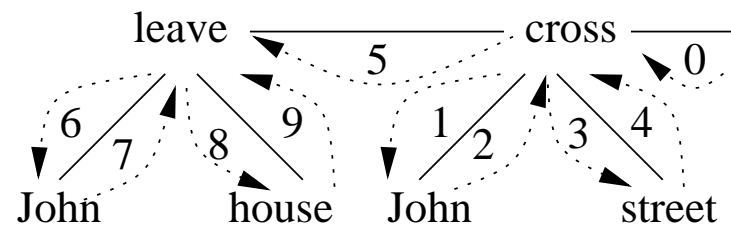

9.2.5 Intrapropositional noun coordination (subject)

(i) semantic relations graph (SRG)

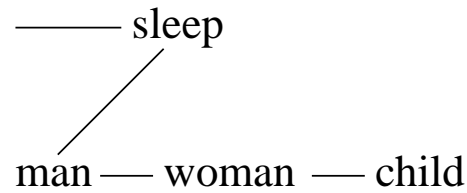

(iii) numbered arcs graph (NAG)

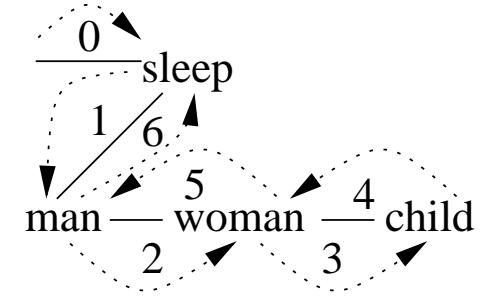

(ii) signature

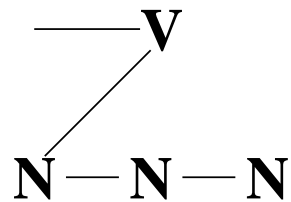

(iv) surface realization

1 2 3 4-5-6
 The_man the_woman and_the_child slept_ .

9.2.6 Extrapositional functor-argument

(i) semantic relations graph (SRG)

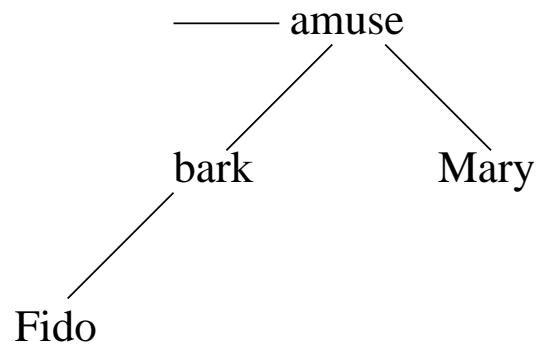

(iii) numbered arcs graph (NAG)

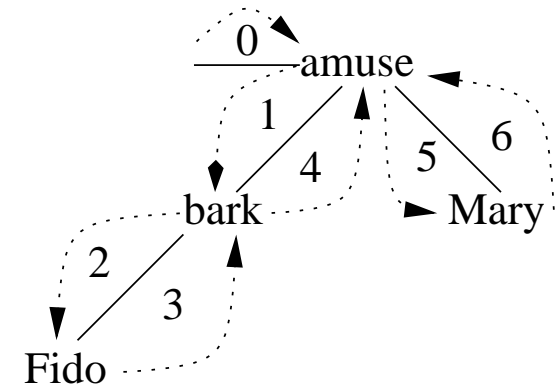

(ii) signature

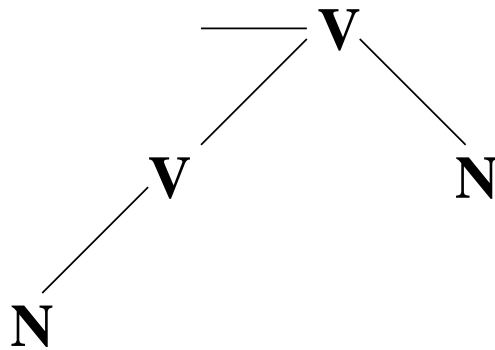

(iv) surface realization

1 2 3 4 5 6
 That Fido barked amused Mary .

9.2.7 Graph-theoretical alternatives for coordination

1. unidirectional

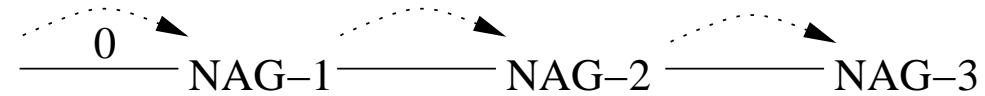

2. bidirectional, symmetric

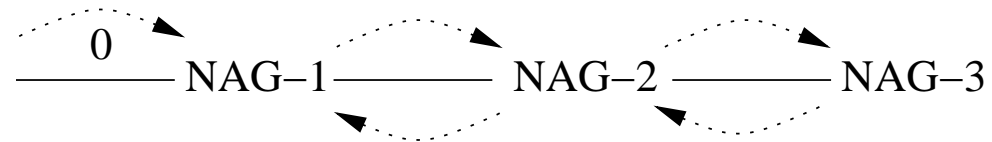

3. bidirectional, asymmetric

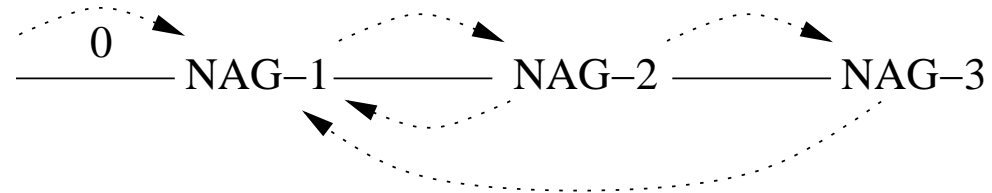

9.3 Sharing in Relative Clauses

9.3.1 Main clauses and equivalent relative clauses

main clause

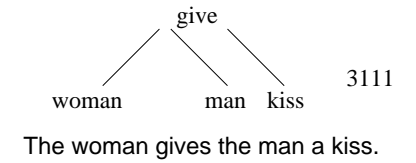
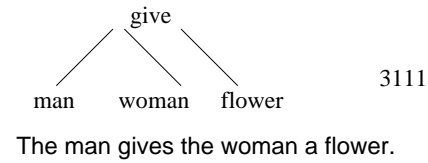
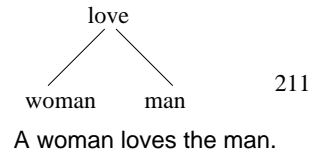
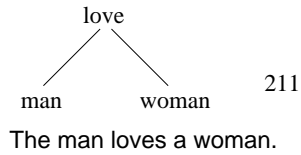
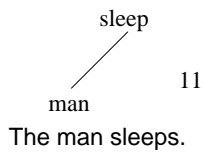

relative clause

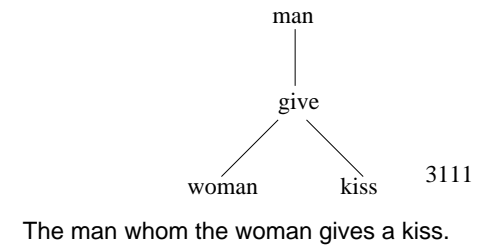
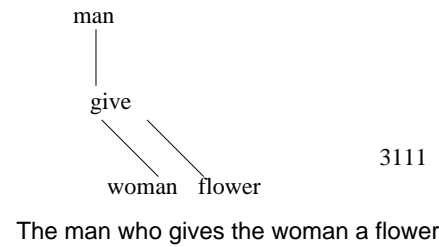
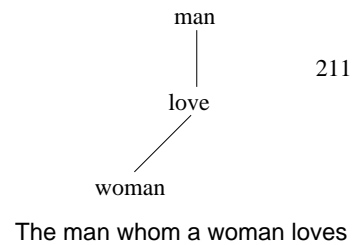
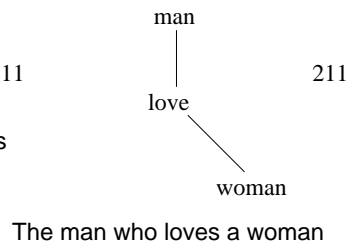
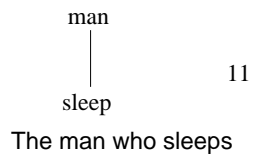

9.3.4 English realization of content 9.3.3

The man who loves the woman who feeds the child sings.

9.3.5 English surface realization of relative clauses

surface realization (English, unmarked)

1	2	3	4	5	6-7-8-9-10
The man	who_loves	the_woman	who_feeds	the_child	sings_ .

9.3.6 Surface realization with extraposed relative clause

surface realization (English, extraposed, marked)

1	10	1-2	3	4	5	6-7-8-9-10
The_man	sings	who_loves	the_woman	who_feeds	the_child	.

9.3.7 Constraint on multiple visits, variant I

In content navigation without language realization, a multiple visit is

1. *permitted* if there are still untraversed arcs in the graph,
2. *prohibited* if all arcs in the graph have been traversed.

9.3.8 Constraint on multiple visits, variant II

In content navigation with language realization, a multiple visit is

1. *permitted* if a required function word has not yet been realized,
2. *prohibited* if there is no value remaining in the current proplet set which has not already been used exhaustively for realization.

9.4 Unbounded Dependencies

9.4.1 DBS graph analysis for John said that Bill believes that Mary loves Tom.

(i) semantic relations graph (SRG)

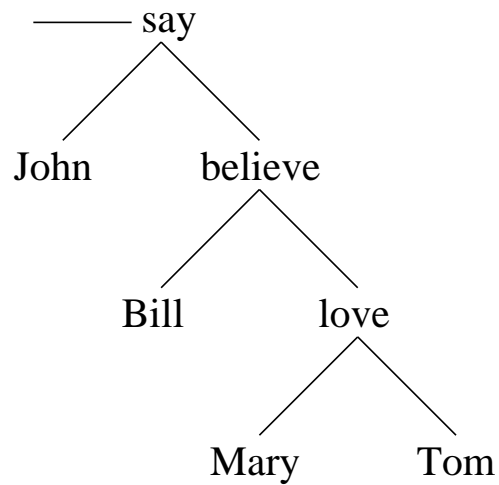

(ii) signature

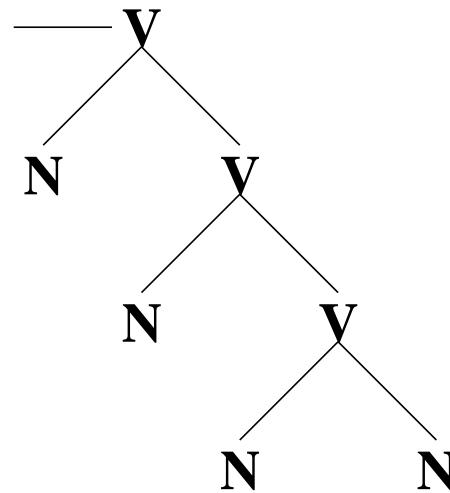

(iii) numbered arcs graph (NAG)

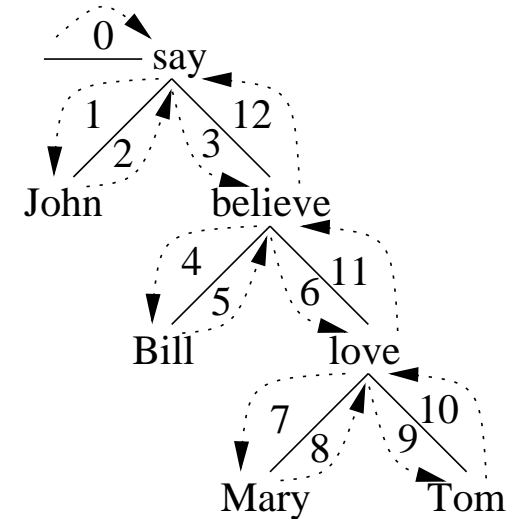

(iv) surface realization

1 2 3 4 5 6 7 8 9 10-11-12
 John said that Bill believes that Mary loves Tom .

9.4.2 NAG and surface realization of Whom did John say that Bill believes that Mary loves?

(iii) numbered arcs graph (NAG)

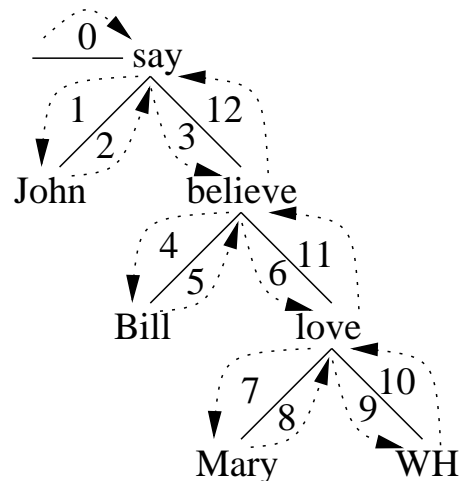

(iv) surface realization

3-6-9 10-11-12 1 2 3 4 5 6 7 8 11-12
 Whom did John say that Bill believes that Mary loves ?

9.4.3 Proplet representation of 9.4.2

$\left[\begin{array}{l} \text{verb: say} \\ \text{arg: John (believe 7)} \\ \text{prn: 6} \end{array} \right]$	$\left[\begin{array}{l} \text{noun: John} \\ \text{fnc: say} \\ \text{prn: 6} \end{array} \right]$	$\left[\begin{array}{l} \text{verb: believe} \\ \text{arg: Bill (love 8)} \\ \text{fnc: (say 6)} \\ \text{prn: 7} \end{array} \right]$	$\left[\begin{array}{l} \text{noun: Bill} \\ \text{fnc: believe} \\ \text{prn: 7} \end{array} \right]$	$\left[\begin{array}{l} \text{verb: love} \\ \text{arg: Mary WH} \\ \text{fnc: (believe 7)} \\ \text{prn: 8} \end{array} \right]$	$\left[\begin{array}{l} \text{noun: Mary} \\ \text{fnc: love} \\ \text{prn: 8} \end{array} \right]$	$\left[\begin{array}{l} \text{noun: WH} \\ \text{fnc: love} \\ \text{prn: 8} \end{array} \right]$
---	---	---	---	--	--	--

9.5 Subject Gapping and Verb Gapping

9.5.1 Subject gapping

Bob ate an apple, # walked the dog, and # read the paper.

9.5.2 Verb gapping

Bob ate an apple, Jim # a pear, and Bill # a peach.

9.5.3 DBS graph analysis of verb gapping in 9.5.2

(i) semantic relations graph (SRG)

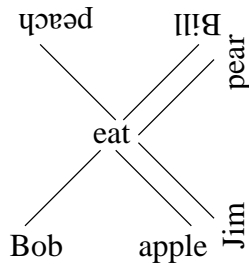

(ii) signature

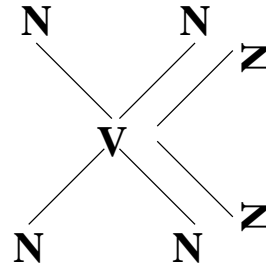

(iii) numbered arcs graph (NAG)

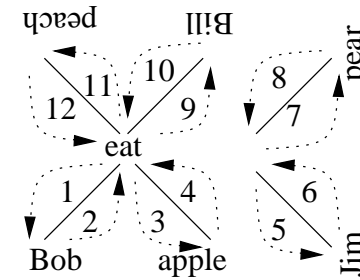

(iv) surface realization

1	2	3	4-5	6-7	8	9	10-11	12
Bob	ate	an_apple	Jim	a_pear	and	Bill	a_peach	.

9.5.4 Verb gapping content as a set of proplets

$\left[\begin{array}{l} \text{noun: Bob} \\ \text{cat: nm} \\ \text{sem: sg} \\ \text{fnc: eat} \\ \text{prn: 31} \end{array} \right]$	$\left[\begin{array}{l} \text{verb: eat} \\ \text{cat: decl} \\ \text{sem: past} \\ \text{arg: Bob apple} \\ \quad \text{Jim pear} \\ \quad \text{Bill peach} \\ \text{prn: 31} \end{array} \right]$	$\left[\begin{array}{l} \text{noun: apple} \\ \text{cat: snp} \\ \text{sem: indef sg} \\ \text{fnc: eat} \\ \text{prn: 31} \end{array} \right]$	$\left[\begin{array}{l} \text{noun: Jim} \\ \text{cat: nm} \\ \text{sem: sg} \\ \text{fnc: eat} \\ \text{prn: 31} \end{array} \right]$	$\left[\begin{array}{l} \text{noun: pear} \\ \text{cat: snp} \\ \text{sem: indef sg} \\ \text{fnc: eat} \\ \text{prn: 31} \end{array} \right]$	$\left[\begin{array}{l} \text{noun: Bill} \\ \text{cat: nm} \\ \text{sem: sg} \\ \text{fnc: eat} \\ \text{prn: 31} \end{array} \right]$	$\left[\begin{array}{l} \text{noun: peach} \\ \text{cat: snp} \\ \text{sem: indef sg} \\ \text{fnc: eat} \\ \text{prn: 31} \end{array} \right]$
---	---	--	---	---	--	--

9.5.5 DBS graph analysis of subject gapping in 9.5.1

(i) semantic relations graph (SRG)

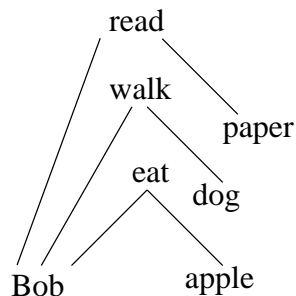

(ii) signature

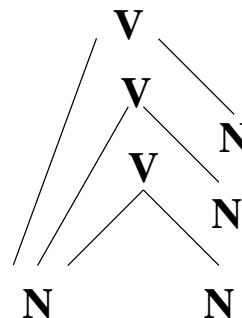

(iii) numbered arcs graph (NAG)

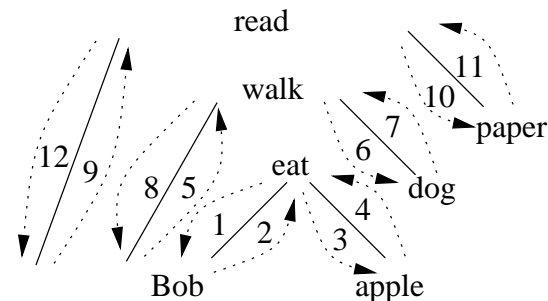

(iv) surface realization

1 2 3 4-1-5 6 7-8-9 10 11-12-2
 Bob ate an_apple walked the_dog and_read the_paper .

9.5.6 Proplet representation of subject gapping

[noun: Bob]		[verb: eat]		[noun: apple]		[verb: walk]		[noun: dog]		[verb: read]		[noun: paper]
cat: nm		cat: decl		cat: snp		cat: decl		cat: snp		cat: decl		cat: snp
sem: sg		sem: past		sem: indef sg		sem: past		sem: def sg		sem: past		sem: def sg
fnc: eat		arg: Bob apple		fnc: eat		arg: Bob dog		fnc: walk		arg: Bob paper		fnc: read
walk		prn: 32		prn: 32		prn: 32		prn: 32		prn: 32		prn: 32
read												
prn: 32												

9.6 Object Gapping and Noun Gapping

9.6.1 Object gapping:

Bob bought #, Jim peeled #, and Bill ate the apple.

9.6.2 Noun gapping:

Bob ate the red #, the green #, and the blue berries.

9.6.3 DBS graph analysis of object gapping in 9.6.1

(i) semantic relations graph (SRG)

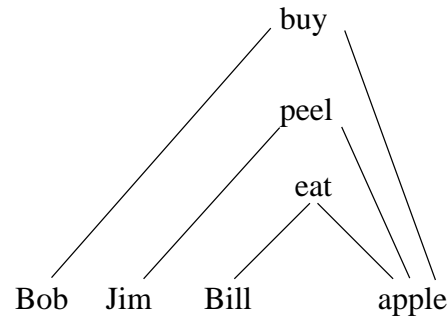

(ii) signature

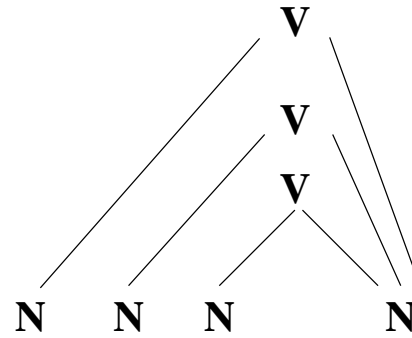

(iii) numbered arcs graph (NAG)

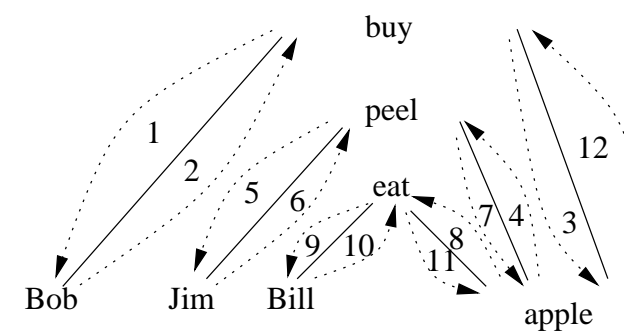

(iv) surface realization

1 2 3-4-5 6 7-8 9 10 11 12
 Bob bought Jim peeled and Bill ate the_apple .

9.6.4 Proplet representation of object gapping

[noun: Bob cat: nm sem: sg fnc: buy prn: 33]	[verb: buy cat: decl sem: past arg: Bob apple prn: 33]	[noun: Jim cat: nm sem: sg fnc: peel prn: 33]	[verb: peel cat: decl sem: past arg: Jim apple prn: 33]	[noun: Bill cat: nm sem: sg fnc: eat prn: 33]	[verb: eat cat: decl sem: past arg: Bill apple prn: 33]	[noun: apple cat: snp sem: def sg fnc: buy peel eat prn: 33]
--	--	---	---	---	---	--

9.6.5 DBS graph analysis of noun gapping in 9.6.2

(i) semantic relations graph (SRG)

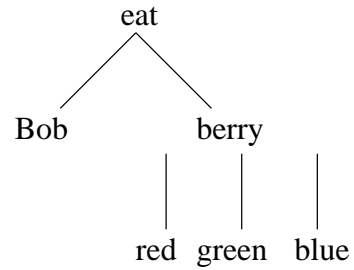

(ii) signature

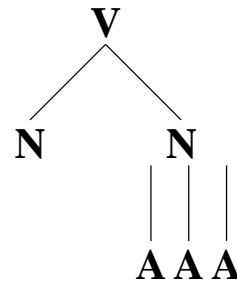

(iii) numbered arcs graph (NAG)

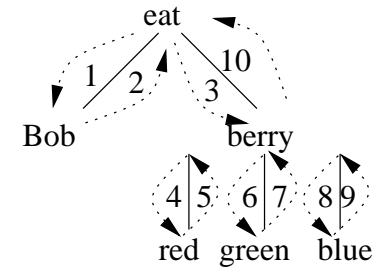

(iv) surface realization

1 2 3 4 5 6 7 8 9 10
 Bob ate the red the green and_the blue berries .

9.6.6 Proplet representation of noun gapping

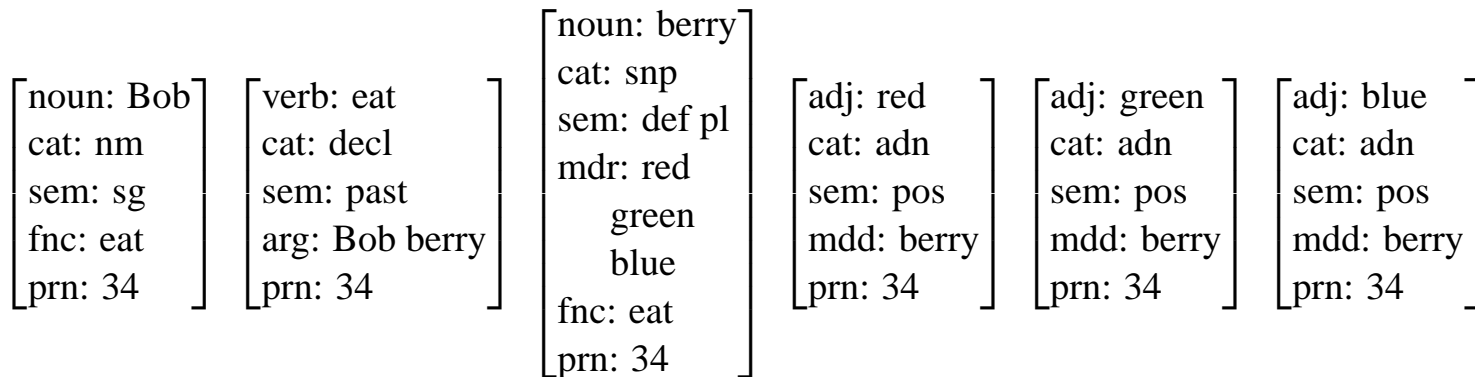

9.6.7 DBS graph analysis of adnominal coordination: Bob ate the red, green, and blue berries.

(i) semantic relations graph (SRG)

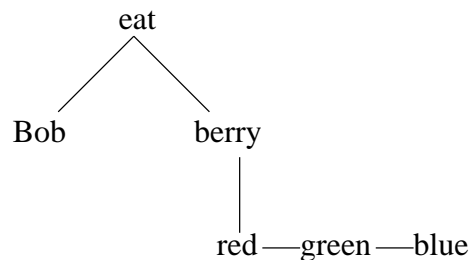

(ii) signature

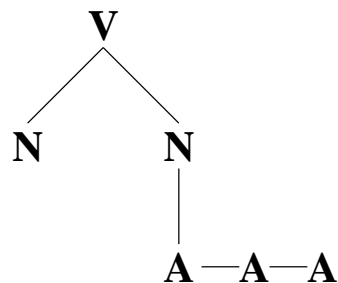

(iii) numbered arcs graph (NAG)

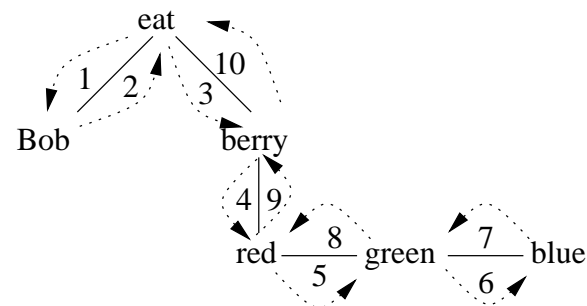

(iv) surface realization

1 2 3 4 5 6 7-8-9 10
 Bob ate the red green and_blue berries .

9.6.8 Proplet representation of adnominal coordination

[noun: Bob cat: nm sem: sg fnc: eat prn: 35]	[verb: eat cat: decl sem: past arg: Bob berry prn: 35]	[noun: berry cat: pnp sem: def pl mdr: red fnc: eat prn: 35]	[adj: red cat: adn sem: pos mdr: berry nc: green pc: prn: 35]	[adj: green cat: adn sem: pos mdr: nc: blue pc: red prn: 35]	[adj: blue cat: adn sem: pos mdr: nc: pc: green prn: 35]
--	--	---	---	--	--

9.6.9 Combination of object gapping and noun gapping

Bob bought #, Jim peeled #, and Bill ate the red #, the green #, and the yellow apple.

10. Computing Perspective in Dialogue

10.1 Agent's STAR-0 Perspective on Current Content

10.1.1 Anchored nonlanguage content

I am writing you a letter.^{STAR-0}

10.1.2 Coding unanchored content as a proplet set

$\left[\begin{array}{l} \text{noun: moi}^1 \\ \text{fnc: write} \\ \text{prn: 659} \end{array} \right]$	$\left[\begin{array}{l} \text{verb: write} \\ \text{arg: moi toi letter} \\ \text{prn: 659} \end{array} \right]$	$\left[\begin{array}{l} \text{noun: toi} \\ \text{fnc: write} \\ \text{prn: 659} \end{array} \right]$	$\left[\begin{array}{l} \text{noun: letter} \\ \text{fnc: write} \\ \text{prn: 659} \end{array} \right]$
--	---	--	---

10.1.3 Specification of a STAR

S = Paris

T = 1930-07-03

A = Jean-Paul Sartre

R = Simone de Beauvoir

10.1.4 STAR-0 content with 1st and 2nd person indexicals

[noun: moi fnc: write prn: 659]	[verb: write arg: moi toi letter prn: 659]	[noun: toi fnc: write prn: 659]	[noun: letter fnc: write prn: 659]	[S: Paris T: 1930-07-03 A: J.-P. Sartre R: S. de Beauvoir prn: 659]
---	--	---	--	---

10.1.5 STAR-0 content without indexicals

[noun: Fido fnc: bark prn: 572]	[verb: bark arg: Fido prn: 572]	[S: Paris T: 1930-07-03 A: S. de Beauvoir prn: 572]
---	---	--

10.1.6 STAR-0 content with a 3rd person indexical

[noun: ça fnc: bark prn: 572]	[verb: bark arg: ça prn: 572]	[S: Paris T: 1930-07-03 A: S. de Beauvoir 3rd: Fido prn: 572]
---------------------------------------	---------------------------------------	---

10.2 Speaker's STAR-1 Perspective on Stored Content

10.2.1 STAR-1 expression with 1st and 2nd person indexicals

I wrote you a letter yesterday.^{STAR-1}

10.2.2 STAR-1.1 inference for temporal specification

$$\left[\begin{array}{l} \text{verb: } \alpha \\ \text{prn: K} \end{array} \right] \left[\begin{array}{l} \text{S: L} \\ \text{T: D} \\ \text{A: N} \\ \text{R: O} \\ \text{prn: K} \end{array} \right] \left[\begin{array}{l} \text{S: L}' \\ \text{T: D}' \\ \text{A: N} \\ \text{R: O}' \\ \text{prn: K+M} \end{array} \right] \Rightarrow \left[\begin{array}{l} \text{verb: } \alpha \\ \text{sem: } \beta \\ \text{mdr: } \gamma \\ \text{prn: K+M} \end{array} \right] \left[\begin{array}{l} \text{adj: } \gamma \\ \text{mdd: } \alpha \\ \text{prn: K+M} \end{array} \right] \left[\begin{array}{l} \text{S: L}' \\ \text{T: D}' \\ \text{A: N} \\ \text{R: O}' \\ \text{prn: K+M} \end{array} \right]$$

If $D < D'$, then $\beta = \text{past}$, and if $D \text{ diff } D' = 1 \text{ day}$, then $\gamma = \text{yesterday}$; and similarly for all the other possible temporal relations between a STAR-0 and a STAR-1 differing in their T value.

10.2.3 STAR-1 content *Moi* wrote *toi* a letter yesterday.

$$\left[\begin{array}{l} \text{noun: moi} \\ \text{fnc: write} \\ \text{prn: 659+7} \end{array} \right] \left[\begin{array}{l} \text{verb: write} \\ \text{arg: moi toi letter} \\ \text{sem: past} \\ \text{mdr: yesterday} \\ \text{prn: 659+7} \end{array} \right] \left[\begin{array}{l} \text{noun: toi} \\ \text{fnc: write} \\ \text{prn: 659+7} \end{array} \right] \left[\begin{array}{l} \text{noun: letter} \\ \text{fnc: write} \\ \text{prn: 659+7} \end{array} \right] \left[\begin{array}{l} \text{adj: yesterday} \\ \text{mdd: write} \\ \text{prn: 659+7} \end{array} \right] \left[\begin{array}{l} \text{S: Paris} \\ \text{T: 1930-07-04} \\ \text{A: J.-P. Sartre} \\ \text{R: S. de Beauvoir} \\ \text{prn: 659+7} \end{array} \right]$$

10.2.4 STAR-1.3 inference for specification of recipient

$$\begin{array}{c} \left[\begin{array}{l} \text{verb: } \alpha \\ \text{arg: } \{X \text{ toi}\} \\ \text{prn: K} \end{array} \right] \left[\begin{array}{l} \text{noun: toi} \\ \text{fnc: } \alpha \\ \text{prn: K} \end{array} \right] \left[\begin{array}{l} \text{S: L} \\ \text{T: D} \\ \text{A: N} \\ \text{R: O} \\ \text{prn: K} \end{array} \right] \left[\begin{array}{l} \text{S: L}' \\ \text{T: D}' \\ \text{A: N} \\ \text{R: O}' \\ \text{prn: K+M} \end{array} \right] \Rightarrow \left[\begin{array}{l} \text{verb: } \alpha \\ \text{arg: } \{X \text{ O}\} \\ \text{prn: K+M} \end{array} \right] \left[\begin{array}{l} \text{noun: O} \\ \text{fnc: } \alpha \\ \text{prn: K+M} \end{array} \right] \left[\begin{array}{l} \text{S: L}' \\ \text{T: D}' \\ \text{A: N} \\ \text{R: O}' \\ \text{prn: K+M} \end{array} \right]
 \end{array}$$

10.2.5 STAR-1 content *Moi* wrote Simone a letter yesterday.

$$\begin{array}{c} \left[\begin{array}{l} \text{noun: moi} \\ \text{fnc: write} \\ \text{prn: 659+7} \end{array} \right] \left[\begin{array}{l} \text{verb: write} \\ \text{arg: moi Simone letter} \\ \text{sem: past} \\ \text{mdr: yesterday} \\ \text{prn: 659+7} \end{array} \right] \left[\begin{array}{l} \text{noun: Simone} \\ \text{fnc: write} \\ \text{prn: 659+7} \end{array} \right] \left[\begin{array}{l} \text{noun: letter} \\ \text{fnc: write} \\ \text{prn: 659+7} \end{array} \right] \left[\begin{array}{l} \text{adj: yesterday} \\ \text{mdd: write} \\ \text{prn: 659+7} \end{array} \right] \left[\begin{array}{l} \text{S: Paris} \\ \text{T: 1930-07-04} \\ \text{A: J.-P. Sartre} \\ \text{R: Juliette} \\ \text{prn: 659+7} \end{array} \right]
 \end{array}$$

10.3 Hearer's STAR-2 Perspective on Language Content

10.3.1 Result of analyzing 10.2.1 in the hear mode

$\left[\begin{array}{l} \text{noun: moi} \\ \text{fnc: write} \\ \text{prn: 623} \end{array} \right]$	$\left[\begin{array}{l} \text{verb: write} \\ \text{arg: moi toi letter} \\ \text{sem: past} \\ \text{mdr: yesterday} \\ \text{prn: 623} \end{array} \right]$	$\left[\begin{array}{l} \text{noun: toi} \\ \text{fnc: write} \\ \text{prn: 623} \end{array} \right]$	$\left[\begin{array}{l} \text{noun: letter} \\ \text{fnc: write} \\ \text{prn: 623} \end{array} \right]$	$\left[\begin{array}{l} \text{adj: yesterday} \\ \text{mdd: write} \\ \text{prn: 623} \end{array} \right]$
--	--	--	---	---

10.3.2 Main hear mode perspectives on language content

1. The perspective of the hearer as the partner in face-to-face communication.
2. The perspective of someone overhearing a conversation between others.
3. The reader's perspective onto the content of a written text (Chap. 11.).

10.3.3 STAR-2.1 inference for deriving hearer perspective

$$\begin{array}{c}
 \left[\begin{array}{l} \text{noun: moi} \\ \text{fnc: } \alpha \\ \text{prn: K} \end{array} \right] \left[\begin{array}{l} \text{verb: } \alpha \\ \text{arg: } \{X \text{ moi toi}\} \\ \text{prn: K} \end{array} \right] \left[\begin{array}{l} \text{noun: toi} \\ \text{fnc: } \alpha \\ \text{prn: K} \end{array} \right] \left[\begin{array}{l} \text{S: L} \\ \text{T: D} \\ \text{A: N} \\ \text{R: O} \\ \text{prn: K} \end{array} \right] \Rightarrow \\
 \left[\begin{array}{l} \text{noun: toi} \\ \text{fnc: } \alpha \\ \text{prn: K} \end{array} \right] \left[\begin{array}{l} \text{verb: } \alpha \\ \text{arg: } \{X \text{ toi moi}\} \\ \text{prn: K} \end{array} \right] \left[\begin{array}{l} \text{noun: moi} \\ \text{fnc: } \alpha \\ \text{prn: K} \end{array} \right] \left[\begin{array}{l} \text{S: L} \\ \text{T: D} \\ \text{A: O} \\ \text{R: N} \\ \text{prn: K} \end{array} \right]
 \end{array}$$

10.3.4 STAR-2 content *Toi* wrote *moi* a letter yesterday.

$$\left[\begin{array}{l} \text{noun: toi} \\ \text{fnc: write} \\ \text{prn: 623} \end{array} \right] \left[\begin{array}{l} \text{verb: write} \\ \text{arg: toi moi letter} \\ \text{sem: past} \\ \text{mdr: yesterday} \\ \text{prn: 623} \end{array} \right] \left[\begin{array}{l} \text{noun: moi} \\ \text{fnc: write} \\ \text{prn: 623} \end{array} \right] \left[\begin{array}{l} \text{noun: letter} \\ \text{fnc: write} \\ \text{prn: 623} \end{array} \right] \left[\begin{array}{l} \text{adj: yesterday} \\ \text{mdd: write} \\ \text{prn: 623} \end{array} \right] \left[\begin{array}{l} \text{S: Paris} \\ \text{T: 1930-07-04} \\ \text{A: Simone de B.} \\ \text{R: J.-P. Sartre} \\ \text{prn: 623} \end{array} \right]$$

10.3.5 STAR-1 content without indexicals

Fido barked.^{STAR-1}

10.3.6 STAR-2.2 inference for content without indexicals

$$\left[\begin{array}{l} \text{verb: } \alpha \\ \text{prn: K} \end{array} \right] \left[\begin{array}{l} \text{S: L} \\ \text{T: D} \\ \text{A: N} \\ \text{R: O} \\ \text{prn: K} \end{array} \right] \Rightarrow \left[\begin{array}{l} \text{verb: } \alpha \\ \text{prn: K} \end{array} \right] \left[\begin{array}{l} \text{S: L} \\ \text{T: D} \\ \text{A: O} \\ \text{R: N} \\ \text{prn: K} \end{array} \right]$$

10.3.7 STAR-2 content Fido barked.

$$\left[\begin{array}{l} \text{noun: Fido} \\ \text{fnc: bark} \\ \text{prn: 572} \end{array} \right] \left[\begin{array}{l} \text{verb: bark} \\ \text{arg: Fido} \\ \text{sem: past} \\ \text{prn: 572} \end{array} \right] \left[\begin{array}{l} \text{S: Paris} \\ \text{T: 1930-07-03} \\ \text{A: J.-P. Sartre} \\ \text{R: Simone de B.} \\ \text{prn: 572} \end{array} \right]$$

10.3.8 Operations of STAR-2 inferences

1. The **S** value of the STAR-1 in the input (matching the antecedent) equals the **S** value of the STAR-2 in the output (derived by the consequent).
2. The **T** value of the STAR-1 in the input equals the **T** value of the STAR-2 in the output.
3. The **A** value of the STAR-1 in the input equals the **R** value of the STAR-2 in the output.
4. The **R** value of the STAR-1 in the input equals the **A** value of the STAR-2 in the output.
5. The **prn** value of the input equals the **prn** value of the output.

10.4 Dialogue with a WH Question and Its Answer

10.4.1 Nonlanguage content in the interrogative mood

What did you write?^{STAR-0}

10.4.2 Anchored STAR-0 content of WH interrogative

[noun: toi fnc: write prn: 625]	[verb: write cat: interrog sem: past arg: toi what prn: 625]	[noun: what fnc: write prn: 625]	[S: Paris T: 1930-07-04 A: Simone de B. R: J.-P. Sartre prn: 625]
---	--	--	---

10.4.3 Questioner as speaker: DBS graph analysis of 10.4.1

(i) *semantic relations graph (SRG)*

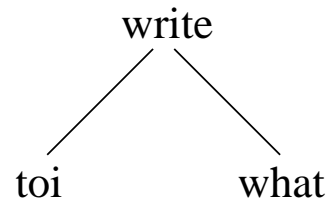

(ii) *signature*

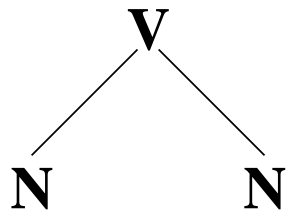

(ii) *numbered arcs graph (NAG)*

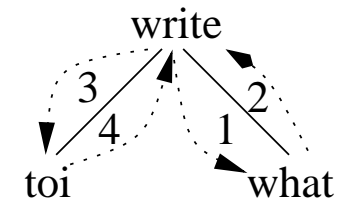

(iv) *surface realization*

1 2 3 4
 What did you write_?

10.4.4 Answerer as hearer parsing 10.4.1

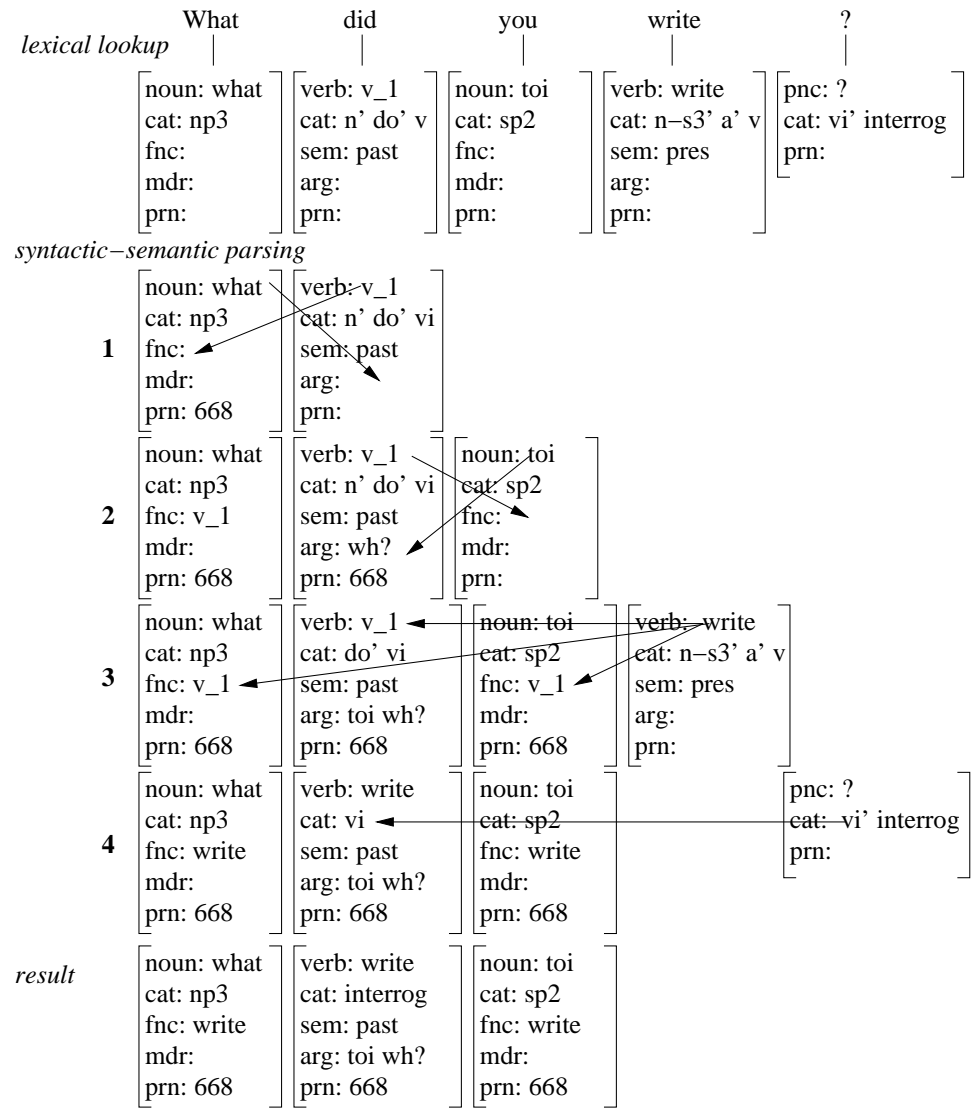

10.4.5 STAR-2.3 inference for deriving hearer perspective

$$\begin{array}{c}
 \left[\begin{array}{l} \text{noun: toi} \\ \text{fnc: } \alpha \\ \text{prn: K} \end{array} \right] \left[\begin{array}{l} \text{verb: } \alpha \\ \text{cat: interrog} \\ \text{arg: } \{X \text{ toi wh}\} \\ \text{prn: K} \end{array} \right] \left[\begin{array}{l} \text{noun: wh} \\ \text{fnc: } \alpha \\ \text{prn: K} \end{array} \right] \left[\begin{array}{l} \text{S: L} \\ \text{T: D} \\ \text{A: N} \\ \text{R: O} \\ \text{prn: K} \end{array} \right] \Rightarrow \\
 \left[\begin{array}{l} \text{noun: moi} \\ \text{fnc: } \alpha \\ \text{prn: K} \end{array} \right] \left[\begin{array}{l} \text{verb: } \alpha \\ \text{cat: interrog} \\ \text{arg: } \{X \text{ moi wh}\} \\ \text{prn: K} \end{array} \right] \left[\begin{array}{l} \text{noun: wh} \\ \text{fnc: } \alpha \\ \text{prn: K} \end{array} \right] \left[\begin{array}{l} \text{S: L} \\ \text{T: D} \\ \text{A: O} \\ \text{R: N} \\ \text{prn: K} \end{array} \right]
 \end{array}$$

10.4.6 Result of applying the STAR-2.3 inference to 10.4.4

$$\left[\begin{array}{l} \text{noun: moi} \\ \text{fnc: write} \\ \text{prn: 668} \end{array} \right] \left[\begin{array}{l} \text{verb: write} \\ \text{cat: interrog} \\ \text{sem: past} \\ \text{arg: moi wh} \\ \text{prn: 668} \end{array} \right] \left[\begin{array}{l} \text{noun: what} \\ \text{fnc: write} \\ \text{prn: 668} \end{array} \right] \left[\begin{array}{l} \text{S: Paris} \\ \text{T: 1930-07-04} \\ \text{A: J.-P. Sartre} \\ \text{R: Simone de B.} \\ \text{prn: 668} \end{array} \right]$$

10.4.7 Answerer as speaker

A little poem.^{STAR-1}

10.4.8 Answer to a WH question as a set of STAR-0 proplets

[noun: poem sem: indef sg mdr: little prn: 655]	[adj: little mdd: poem prn: 655]	[S: Paris T: 1930-07-03 A: J.-P. Sartre R: Simone de B. prn: 655]
--	--	---

10.4.9 Questioner as hearer parsing 10.4.7

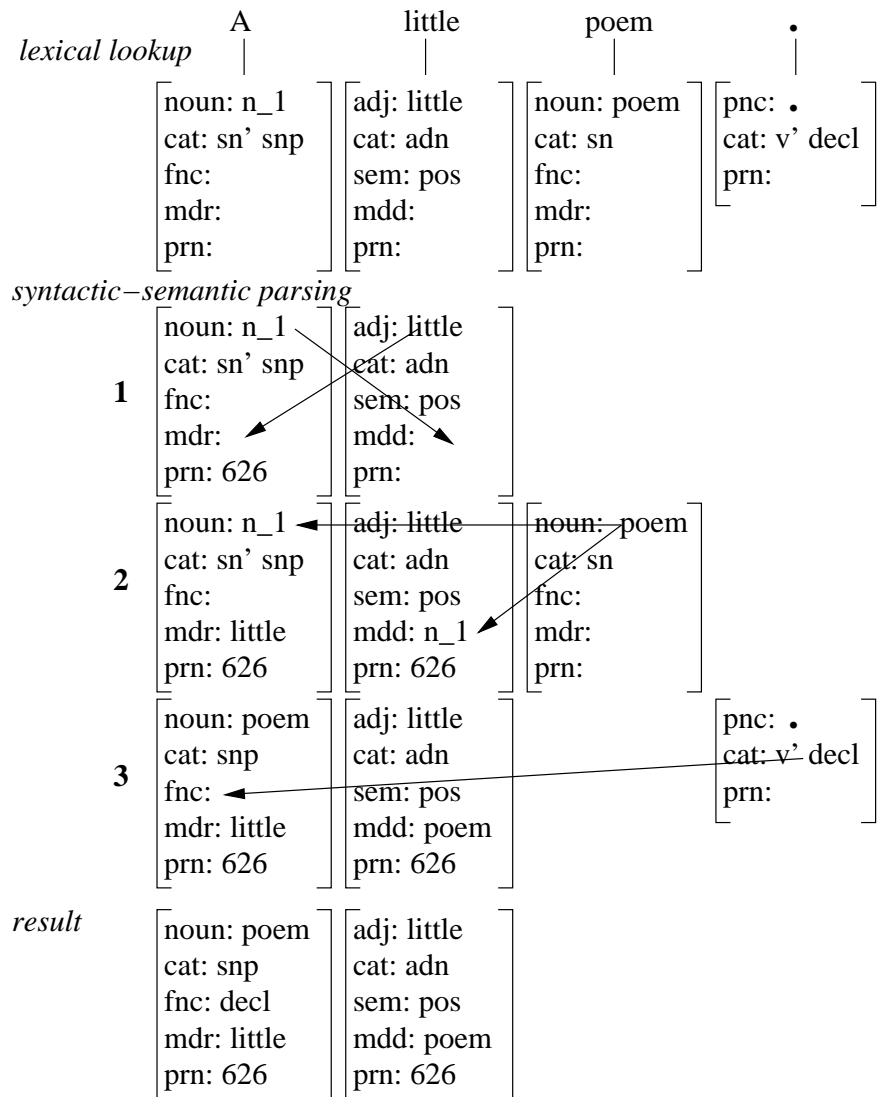

10.4.10 STAR-2.4 connecting WH interrogative with answer

$$\begin{array}{c} \left[\begin{array}{l} \text{verb: } \alpha \\ \text{cat: interrog} \\ \text{arg: } \{ X \text{ toi what} \} \\ \text{prn: K} \end{array} \right] \left[\begin{array}{l} \text{noun: what} \\ \text{fnc: } \alpha \\ \text{prn: K} \end{array} \right] \left[\begin{array}{l} \text{S: L} \\ \text{T: D} \\ \text{A: N} \\ \text{R: O} \\ \text{prn: K} \end{array} \right] + \left[\begin{array}{l} \text{noun: } \beta \\ \text{fnc: decl} \\ \text{mdr: } \gamma \\ \text{prn: K+M} \end{array} \right] \left[\begin{array}{l} \text{adj: } \gamma \\ \text{mdd: } \beta \\ \text{prn: K+M} \end{array} \right] \Rightarrow \\ \\ \left[\begin{array}{l} \text{verb: } \alpha \\ \text{cat: decl} \\ \text{arg: } \{ X \text{ toi } \beta \} \\ \text{prn: K+1} \end{array} \right] \left[\begin{array}{l} \text{noun: } \beta \\ \text{mdr: } \gamma \\ \text{fnc: } \alpha \\ \text{prn: K+M} \end{array} \right] \left[\begin{array}{l} \text{adj: } \gamma \\ \text{mdd: } \beta \\ \text{prn: K+M} \end{array} \right] \left[\begin{array}{l} \text{S: L} \\ \text{T: D} \\ \text{A: N} \\ \text{R: O} \\ \text{prn: K+1} \end{array} \right]
 \end{array}$$

10.4.11 Questioner's STAR-2 content for regaining balance

$$\left[\begin{array}{l} \text{noun: toi} \\ \text{fnc: write} \\ \text{prn: 625+2} \end{array} \right] \left[\begin{array}{l} \text{verb: write} \\ \text{cat: decl} \\ \text{sem: past} \\ \text{arg: toi poem} \\ \text{prn: 625+2} \end{array} \right] \left[\begin{array}{l} \text{noun: poem} \\ \text{fnc: write} \\ \text{mdr: little} \\ \text{prn: 625+2} \end{array} \right] \left[\begin{array}{l} \text{adj: little} \\ \text{mdd: poem} \\ \text{prn: 625+2} \end{array} \right] \left[\begin{array}{l} \text{S: Paris} \\ \text{T: 1930-07-04} \\ \text{A: Simone de B.} \\ \text{R: J.-P. Sartre} \\ \text{prn: 625+2} \end{array} \right]$$

10.5 Dialogue with a Yes/No Question and Its Answer

10.5.1 STAR-0 content underlying language countermeasure

Is the poem about me?^{STAR-0}

10.5.2 Answerer as hearer parsing a yes/no interrogative

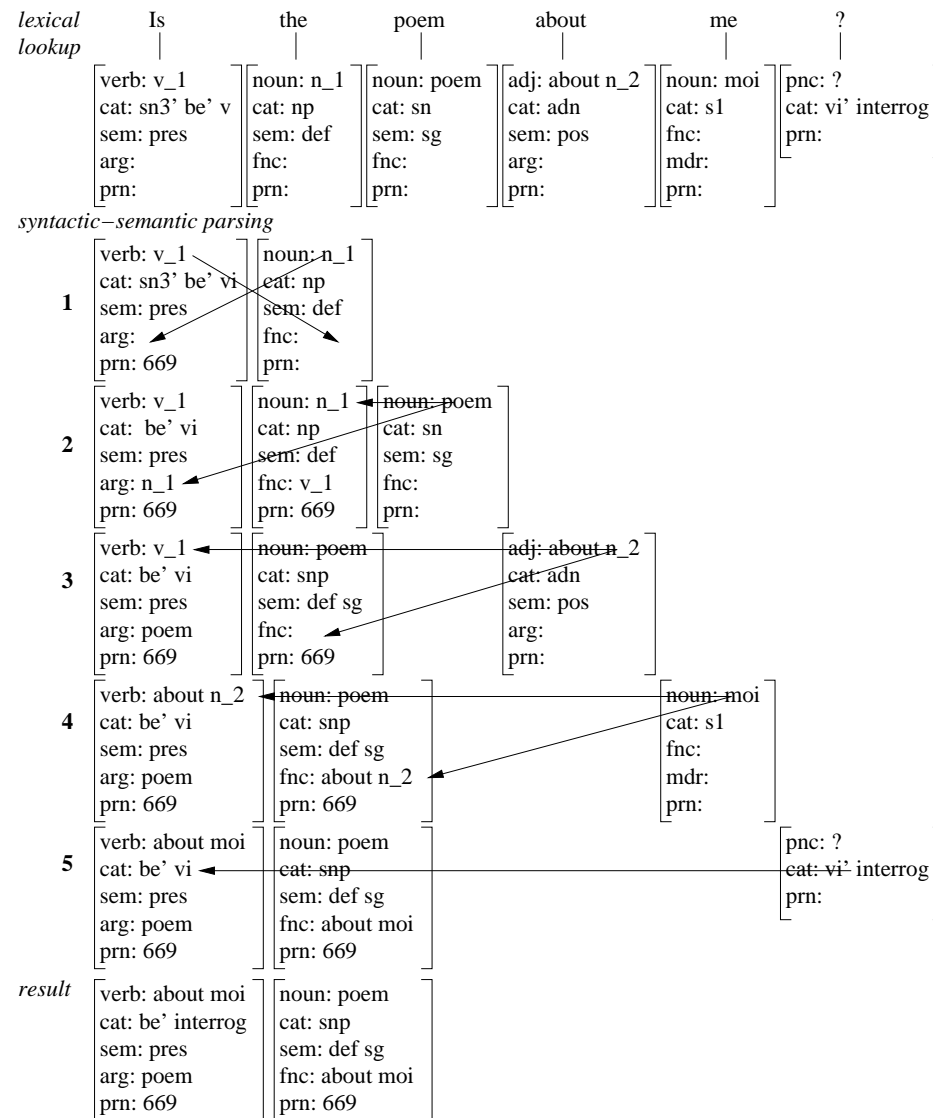

10.5.3 Answerer as hearer: revised perspective of 10.5.2

[noun: poem]	[verb: about toi]	[S: Paris]
cat: snp	cat: be' interrog	T: 1930-07-04
sem: indef sg	sem: pres	A: J.-P. Sartre
fnc: about toi	arg: poem	R: Simone de B.
prn: 669	prn: 669	prn: 669

10.5.4 Answerer J.-P. as speaker

Yes.^{STAR-1}

10.6 Dialogue with Request and Its Fulfillment

10.6.1 Anchored nonlanguage request content

(Please)² pass the ashtray!^{STAR-0}

10.6.2 Request STAR-0 content as a set of proplets

[verb: pass	[noun: ashtray]	[S: Paris
cat: impv	cat: snp	T: 1930-07-04
sem: pres	sem: def sg	A: Simone de B.
arg: # ashtray	fnc: pass	R: J.-P. Sartre
prn: 630	prn: 630	prn: 630

10.6.3 Graph structure used by requestor as speaker

semantic relations

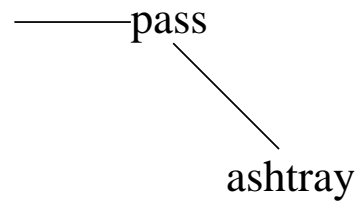

signature

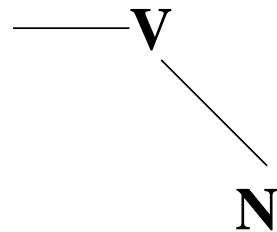

numbered arcs graph (NAG)

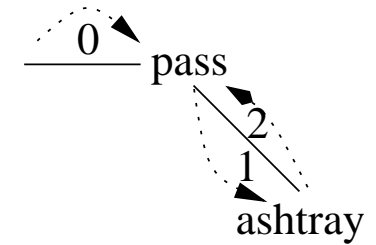

surface realization

0	1	2
Pass	the_ashtray	!

10.6.4 Requestee as hearer parsing Pass the ashtray!

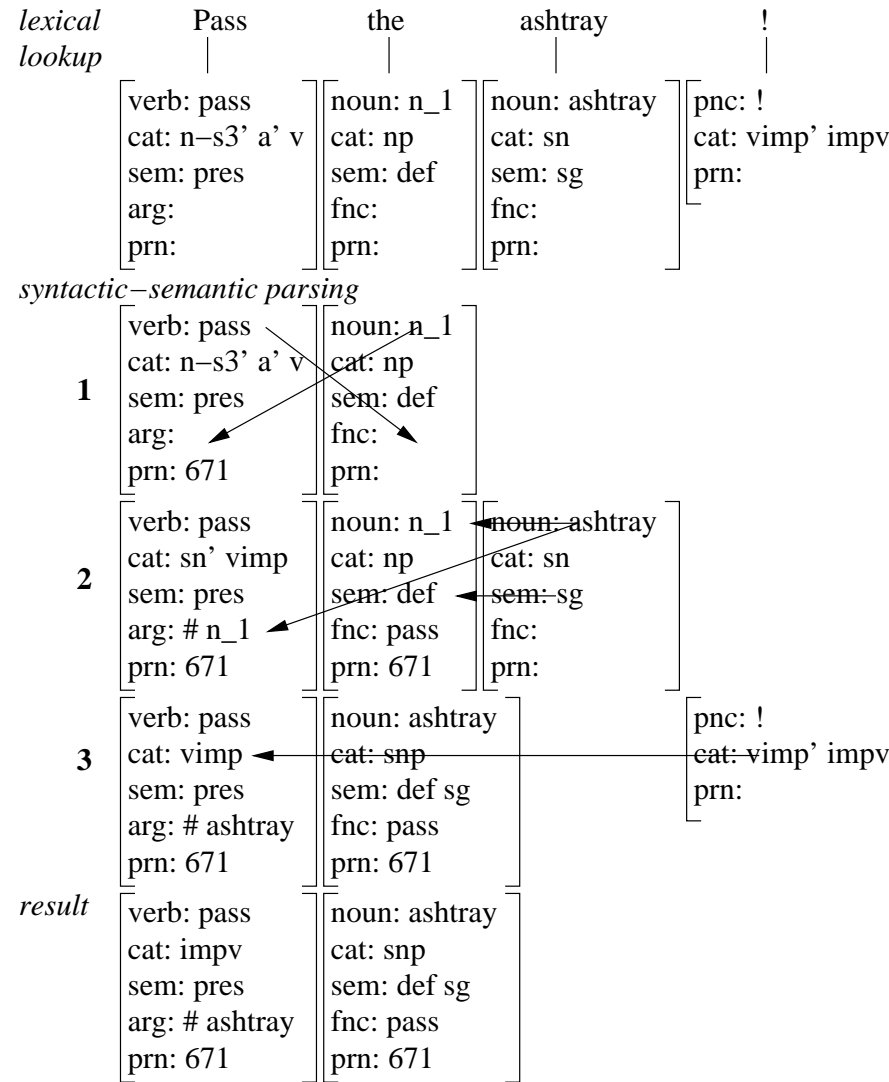

10.6.5 Request STAR-2 content as a set of proplets

[verb: pass	[noun: ashtray	[S: Paris
cat: impv	cat: snp	T: 1930-07-04
sem: pres	sem: def sg	A: J.-P. Sartre
arg: # ashtray	fnc: pass	R: Simone de B.
prn: 671	prn: 671	prn: 671

10.6.6 Sequence of elementary dialogues

- J.-P. Sartre: I wrote you a letter yesterday. (statement, Sect. 10.1–10.3)
S. de Beauvoir: What did you write? (WH question, Sect. 10.4)
J.-P. Sartre: A little poem. (WH answer, Sect. 10.4)
S. de Beauvoir: Is the poem about me? (Yes/No question, Sect. 10.5)
J.-P. Sartre : Yes. (Yes/No answer, Sect. 10.5)
S. de Beauvoir: (Please) pass the ashtray! (request, Sect. 10.6)
J.-P. Sartre: fullfils request (fullfilment, Sect. 10.6)

10.6.7 Perspective conversions as time-linear sequences

1. Statement

STAR-0: emergence of a nonlanguage content in agent A (Sect. 10.1)

STAR-1: production of a statement by agent A as the speaker (Sect. 10.2)

STAR-2: interpretation of statement by agent B as the hearer (Sect. 10.3)

2. Question Dialogue (WH (Sect. 10.4) and Yes/No (Sect.10.5) questions)

STAR-0: emergence of a nonlang. content in agent A as the questioner

STAR-1: production of a question by agent A as the speaker

STAR-2: interpretation of the question by agent B as the hearer

STAR-1: production of an answer by agent B as the speaker

STAR-2: interpretation of the answer by agent A as the hearer

3. Request Dialogue (Sect. 10.6)

STAR-0: emergence of a nonlanguage content in agent A as the requestor

STAR-1: production of a request by agent A as the speaker

STAR-2: interpretation of the request by agent B as the hearer

STAR-1: nonlang. or lang. fulfillment action by agent B as the requestee

STAR-2: nonlanguage or language fulfillment recognition by agent A as the requestor

11. Computing Perspective in Text

11.1 Coding the STAR-1 in Written Text

11.1.1 Text with a dispersed coding of the STAR-1

Jan. 16th, 1832 – The neighbourhood of Porto Praya, viewed from the sea, wears a desolate aspect. The volcanic fire of past ages, and the scorching heat of the tropical sun, have in most places rendered the soil steril and unfit for vegetation. The country rises in successive steps of table land, interspersed with some truncate conical hills, and the horizon is bounded by an irregular chain of more lofty mountains. The scene, as beheld through the hazy atmosphere of this climate, is one of great interest; if, indeed, a person, fresh from the sea, and who has just walked, for the first time, in a grove of cocoa-nut trees, can be a judge of anything but his own happiness.

Charles Darwin 1839, *Voyage of the Beagle*, p. 41

11.2 Direct Speech in Statement Dialogue

11.2.1 Direct speech in a statement content

John said to Mary: *moi love toi*. Mary said to John: *moi love toi*.^{STAR-1}

11.2.2 Representing the content of 11.2.1 as a set of proplets

$\left[\begin{array}{l} \text{noun: John} \\ \text{fnc: say} \\ \text{prn: 23} \end{array} \right]$	$\left[\begin{array}{l} \text{verb: say} \\ \text{arg: John to_Mary (love 24)} \\ \text{nc: (say 25)} \\ \text{prn: 23} \end{array} \right]$	$\left[\begin{array}{l} \text{adj: to_Mary} \\ \text{fnc: say} \\ \text{prn: 23} \end{array} \right]$	$\left[\begin{array}{l} \text{noun: moi} \\ \text{fnc: love} \\ \text{prn: 24} \end{array} \right]$	$\left[\begin{array}{l} \text{verb: love} \\ \text{arg: moi toi} \\ \text{fnc: (say 23)} \\ \text{prn: 24} \end{array} \right]$	$\left[\begin{array}{l} \text{noun: toi} \\ \text{fnc: love} \\ \text{prn: 24} \end{array} \right]$
$\left[\begin{array}{l} \text{noun: Mary} \\ \text{fnc: say} \\ \text{prn: 25} \end{array} \right]$	$\left[\begin{array}{l} \text{verb: say} \\ \text{arg: Mary to_John (love 26)} \\ \text{pc: (say 23)} \\ \text{prn: 25} \end{array} \right]$	$\left[\begin{array}{l} \text{adj: to_John} \\ \text{fnc: say} \\ \text{prn: 25} \end{array} \right]$	$\left[\begin{array}{l} \text{noun: moi} \\ \text{fnc: love} \\ \text{prn: 26} \end{array} \right]$	$\left[\begin{array}{l} \text{verb: love} \\ \text{arg: moi toi} \\ \text{fnc: (say 25)} \\ \text{prn: 26} \end{array} \right]$	$\left[\begin{array}{l} \text{noun: toi} \\ \text{fnc: love} \\ \text{prn: 26} \end{array} \right]$

11.2.3 STAR-2.5 inference interpreting *moi/toi* in quoted speech

$\left[\begin{array}{l} \text{verb: } \gamma \\ \text{arg: U } \delta \text{ Z } (\beta \text{ K}) \\ \text{prn: K-1} \end{array} \right]$	$\left[\begin{array}{l} \text{noun: } \alpha \\ \text{fnc: } \beta \\ \text{prn: K} \end{array} \right]$	$\left[\begin{array}{l} \text{verb: } \beta \\ \text{arg: X } \alpha \text{ Y} \\ \text{fnc: } (\gamma \text{ K-1}) \\ \text{prn: K} \end{array} \right]$	where $\alpha \in \{\text{moi, toi}\}$ and $\gamma \in \{\text{say, tell, ...}\} \Rightarrow$	if U = NIL, then $\delta = \text{moi}$ otherwise, $\delta = \text{toi}$
---	---	--	--	--

11.2.4 nonlanguage inferences for maintaining balance

1. R(eactor) inferences for recognizing an imbalance and deriving a countermeasure (5.2.1–5.2.3).
2. D(educator) inferences for establishing meaning and event relations (5.3.1–5.3.3).
3. D inferences for creating summaries (5.3.5, 6.5.4, 6.5.5).
4. Consequence inferences **CIN** and **CIP** (6.3.6, 6.3.7).
5. Meta-inference for deriving **up** and **down** inferences for hierarchies (6.5.7).
6. The resulting inferences for performing upward and downward traversal in a hierarchy (6.5.9, 6.5.12).
7. E(ffector) inferences for deriving blueprints for action (5.2.1, 5.2.5, 5.5.5).
8. E inference for changing subjunctive to imperative content (5.6.1).

11.2.5 Language inferences for adjusting perspective

1. STAR-1 inferences deriving the speaker's perspective on Spatial, Temporal (10.2.2), and Recipient (10.2.4) aspects of STAR-0 contents.
2. STAR-2 inferences deriving the hearer's perspective on contents with (10.3.4, 10.4.5) and without (10.3.6) 1st and 2nd person indexicals.
3. STAR-2 inference combining question with answer content (10.4.10).
4. STAR-2 inference interpreting *moi/toi* in quoted speech (11.2.3).
5. STAR-2 inference interpreting *ça* coreferentially (11.3.6)

11.3.4 Indexical STAR-0 representation as a proplet set

$\left[\begin{array}{l} \text{noun: Mary} \\ \text{cat: nm} \\ \text{sem: sg f} \\ \text{fnc: know} \\ \text{prn: 89} \end{array} \right]$	$\left[\begin{array}{l} \text{verb: know} \\ \text{cat: decl} \\ \text{sem: past} \\ \text{arg: Mary (happy 90)} \\ \text{prn: 89} \end{array} \right]$	$\left[\begin{array}{l} \text{noun: } \zeta a \\ \text{cat: s3} \\ \text{sem: sg f} \\ \text{fnc: happy} \\ \text{prn: 90} \end{array} \right]$	$\left[\begin{array}{l} \text{verb: happy} \\ \text{cat: v} \\ \text{sem: past} \\ \text{arg: } \zeta a \\ \text{fnc: (know 89)} \\ \text{prn: 90} \end{array} \right]$	$\left[\begin{array}{l} \text{S: Austin} \\ \text{T: 1974-09-12} \\ \text{A: Peter} \\ \text{3rd: Suzy} \\ \text{prn: 89} \end{array} \right]$
---	--	--	--	---

11.3.5 Coreferential STAR-0 representation as a proplet set

$\left[\begin{array}{l} \text{noun: Mary} \\ \text{cat: nm} \\ \text{sem: sg f} \\ \text{fnc: know} \\ \text{prn: 93} \end{array} \right]$	$\left[\begin{array}{l} \text{verb: know} \\ \text{cat: decl} \\ \text{sem: past} \\ \text{arg: Mary (happy 94)} \\ \text{prn: 93} \end{array} \right]$	$\left[\begin{array}{l} \text{noun: } \zeta a \\ \text{cat: s3} \\ \text{sem: sg f} \\ \text{fnc: happy} \\ \text{prn: 94} \end{array} \right]$	$\left[\begin{array}{l} \text{verb: happy} \\ \text{cat: v} \\ \text{sem: past} \\ \text{arg: } \zeta a \\ \text{fnc: (know 93)} \\ \text{prn: 94} \end{array} \right]$	$\left[\begin{array}{l} \text{S: Austin} \\ \text{T: 1974-09-12} \\ \text{A: Peter} \\ \text{prn: 93} \end{array} \right]$
---	--	--	--	---

11.3.6 Inference for the coreferential interpretation of ζa

$$\left[\begin{array}{l} \text{noun: } \alpha \\ \text{prn: K} \end{array} \right] \cdots \left[\begin{array}{l} \text{noun: } \zeta a \\ \text{prn: K+M} \end{array} \right] \Longrightarrow \left[\begin{array}{l} \text{noun: } (\alpha K) \\ \text{prn: K+M} \end{array} \right]$$

11.4 Langacker-Ross Constraint for Sentential Arguments

11.4.1 Pronoun in subject sentence constructions

1. LH' Coreferent noun in lower clause (L) precedes pronoun in matrix (H')
That *Mary* was happy surprised *her*.
2. H'L Pronoun in matrix (H') precedes non-coref. noun in lower clause (L)
% *She* was surprised that *Mary* was happy.
3. L'H Pronoun in lower clause (L') precedes coreferent noun in matrix (H)
That *she* was happy surprised *Mary*.
4. HL' Coreferent noun in matrix (H) precedes pronoun in lower clause (L')
Mary was surprised that *she* was happy.

11.4.2 Subject sentence: Pronoun in higher clause (matrix)

1. **LH'**: That *Mary* was happy surprised *her*.
2. **H'L**: % *She* was surprised that *Mary* was happy.

(i) *semantic relations graph (SRG)*

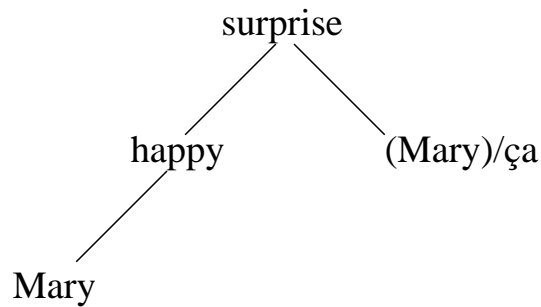

(iii) *numbered arcs graphs (NAG)*

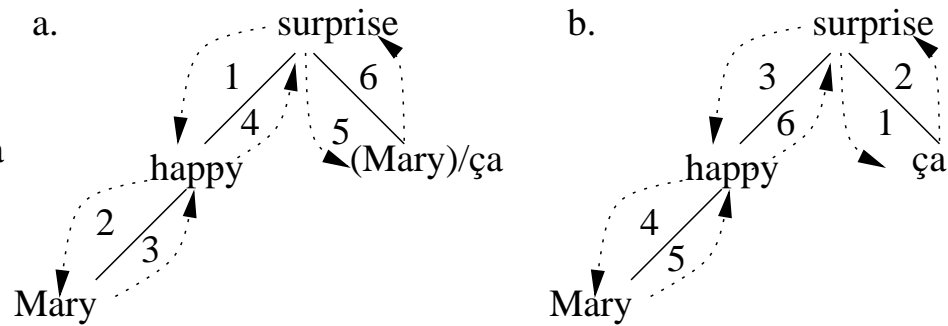

(ii) *signature*

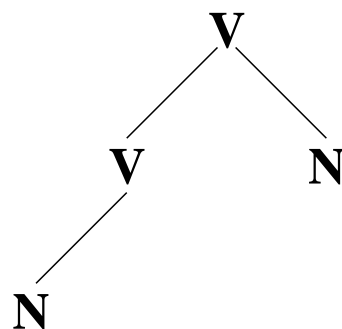

(iv) *surface realization*

a.	1	2	3	4	5	6
	That	Mary	was_happy	surprised	her	.
b.	1	2	3	4	5	6
	% She	was_surprised	that	Mary	was_happy	.

11.4.3 Subject sentence: Pronoun in lower clause

3. **L'H**: That *she* was happy surprised *Mary*.

4. **HL'**: *Mary* was surprised that *she* was happy.

(i) *semantic relations graph (SRG)*

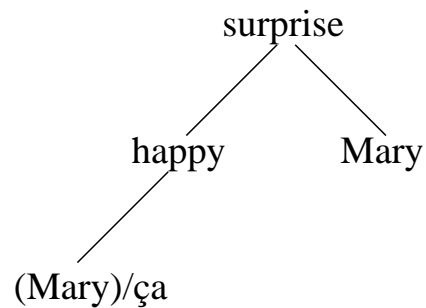

(iii) *s numbered arcs graphs (NAG)*

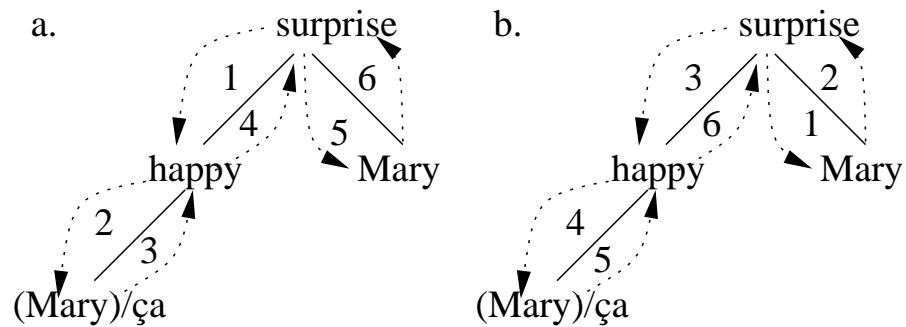

(ii) *signature*

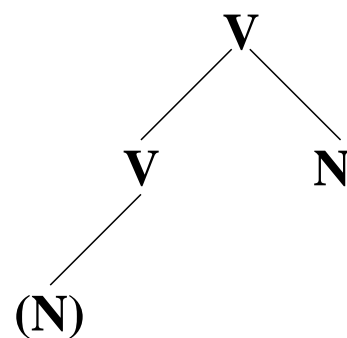

(iv) *surface realization*

a.	1	2	3	4	5	6
	That	she	was_happy	surprised	Mary	.
b.	1	2	3	4	5	6
	Mary	was_surprised	that	she	was_happy	.

11.4.4 Pronoun in object sentence constructions

1. LH' Coreferent noun in lower clause (L) precedes pronoun in matrix (H')
That *Mary* was happy was known to *her*.
2. H'L Pronoun in matrix (H') precedes non-coref. noun in lower clause (L)
% *She* knew that *Mary* was happy.
3. L'H Pronoun in lower clause (L') precedes coreferent noun in matrix (H)
That *she* was happy was known to *Mary*.
4. HL' Coreferent noun in matrix (H) precedes pronoun in lower clause (L')
Mary knew that *she* was happy.

11.4.5 Object sentence: Pronoun in higher clause (matrix)

1. **LH'**: That *Mary* was happy was known to *her*.
2. **H'L**: % *She* knew that *Mary* was happy.

(i) *semantic relations graph (SRG)*

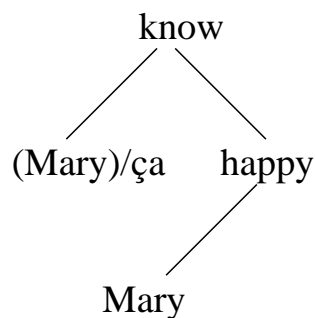

(iii) *numbered arcs graph (NAG)*

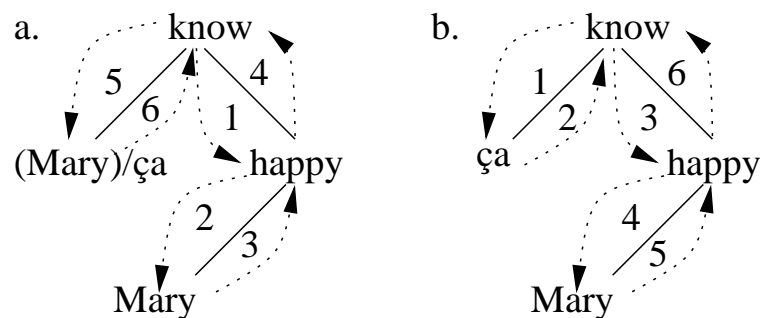

(ii) *signature*

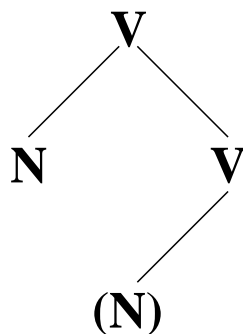

(iv) *surface realization*

- a. 1 2 3 4 5 6
 That Mary was_happy was_known to_her .
- b. 1 2 3 4 5 6
 % She knew that Mary was_happy .

11.4.6 Object sentence: Pronoun in lower clause

3. **L'H**: That *she* was happy was known to *Mary*.

4. **HL'**: *Mary* knew that *she* was happy.

(i) *semantic relations graph (SRG)*

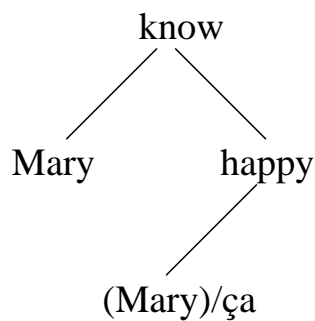

(iii) *numbered arcs graph (NAG)*

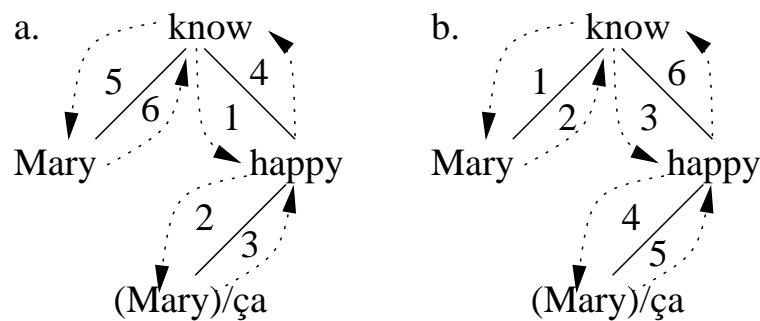

(ii) *signature*

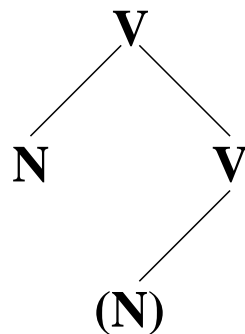

(iv) *surface realization*

- a. 1 2 3 4 5 6
 That she was_happy was_known to_Mary .
- b. 1 2 3 4 5 6
 Mary knew that she was_happy .

11.5 Coreference in Adnominal Sentential Modifiers

11.5.1 Pronoun in Adnominal Modifier Constructions

1. LH' Coreferent noun in lower clause (L) precedes pronoun in matrix (H')
The man who loves *the woman* kissed *her*.
2. H'L Pronoun in matrix (H') precedes non-coref. noun in lower clause (L)
% *She* was kissed by the man who loves *the woman*.
3. L'H Pronoun in lower clause (L') precedes coreferent noun in matrix (H)
The man who loves *her* kissed *the woman*.
4. HL' Coreferent noun in matrix (H) precedes pronoun in lower clause (L')
The woman was kissed by the man who loves *her*.

11.5.2 Adnominal modifier sentence: Pronoun in higher clause

1. **LH'**: The man who loves *the woman* kissed *her*.
2. **H'L**: % *She* was kissed by the man who loves *the woman*.

(i) semantic relations graph (SRG)

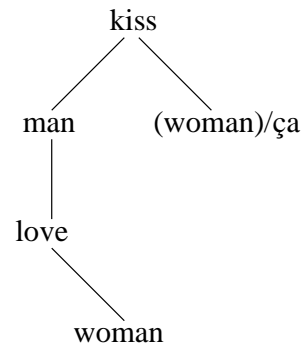

(iii) numbered arcs graph (NAG)

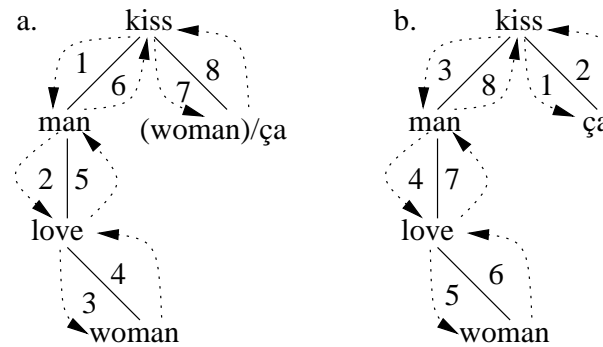

(ii) signature

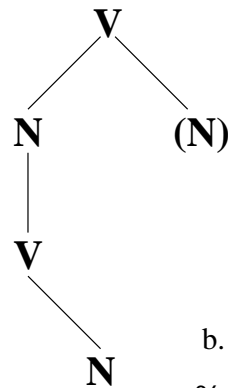

(iv) surface realization

a.	1	2	3	4-5-6	7	8
	The_man	who_loves	the_woman	kissed	her	.
b.	1	2	3	4	5	6-7-8
	% She	was_kissed	by_the_man	who_loves	the_woman	.

11.5.3 Adnominal modifier sentence: Pronoun in lower clause

3. **L'H**: The man who loves *her* kissed *the woman*.

4. **HL'**: *The woman* was kissed by the man who loves *her*.

(i) semantic relations graph (SRG)

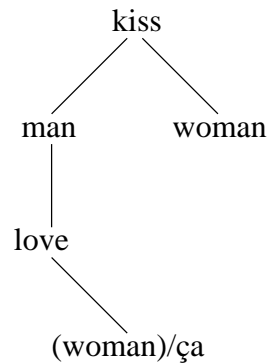

(iii) numbered arcs graph (NAG)

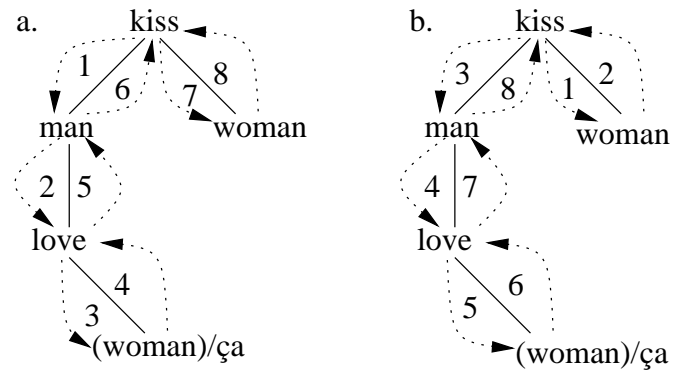

(ii) signature

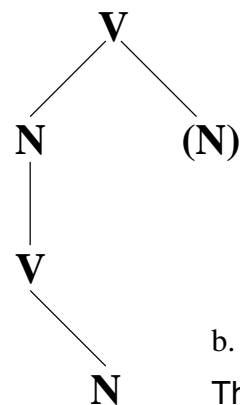

(iv) surface realization

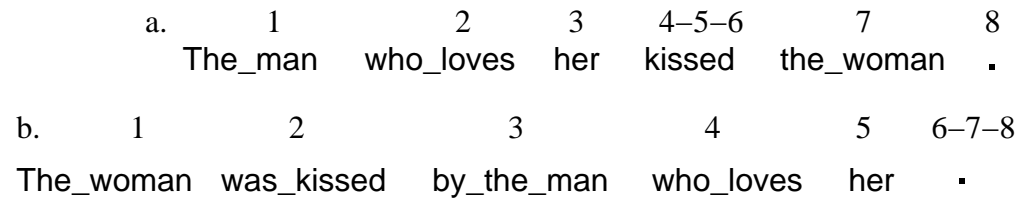

11.5.4 The Donkey sentence

Every farmer who owns a donkey beats it.

11.5.5 Quantifier structure attributed to a Donkey sentence

$$\forall x [[\text{farmer}(x) \wedge \exists y [\text{donkey}(y) \wedge \text{own}(x,y)]] \rightarrow \text{beat}(x,y)]$$

11.5.6 DBS graph analysis of the Donkey sentence

(i) *semantic relations graph (SRG)*

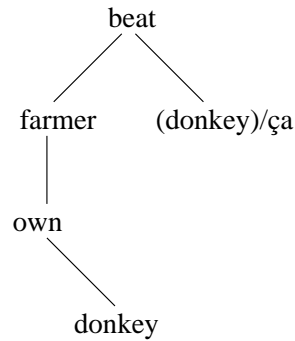

(ii) *signature*

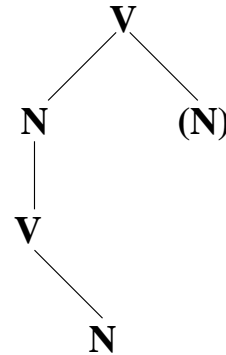

(iii) *numbered arcs graph (NAG)*

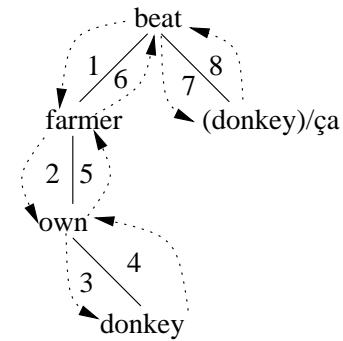

(iv) *surface realization*

1 2 3 4-5-6 7 8
 Every_farmer who_owns a_donkey beats it .

11.5.7 Representing the Donkey content as a set of proplets

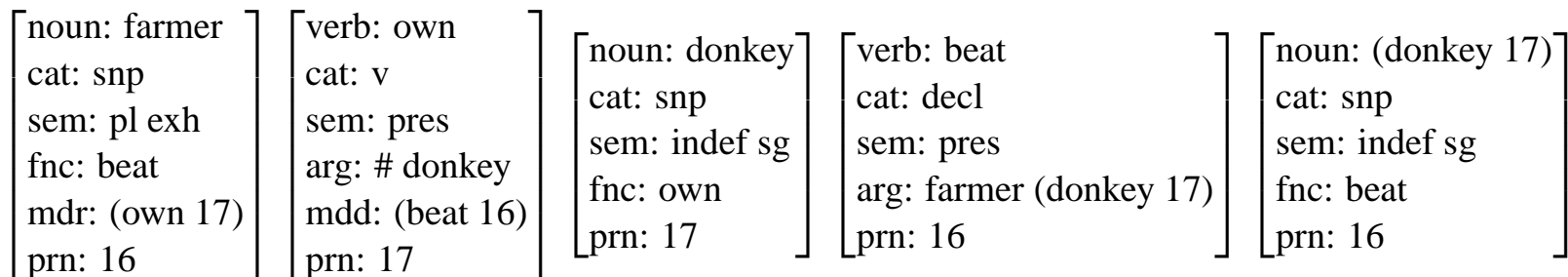

11.5.8 The Bach-Peters sentence

The man who deserves it will get the prize he wants.

11.5.9 DBS graph analysis of the Bach-Peters sentence

(i) semantic relations graph (SRG)

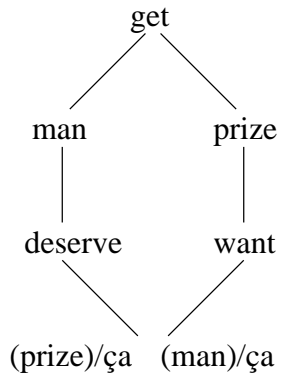

(ii) signature

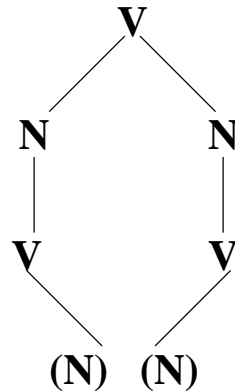

(iii) numbered arcs graph (NAG)

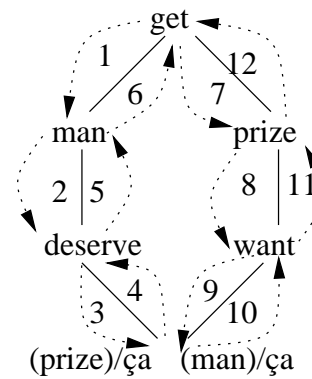

(iv) surface realization

1 2 3 4-5-6 7 8-9 10 11-12
 The_man who_deserves it will_get the_prize he wants .

11.5.10 Proplet representation of the Bach-Peters sentence

[noun: man cat: snp sem: def sg fnc: get mdr: (deserve 57) prn: 56]	[verb: deserve cat: v sem: ind pres arg: # (prize 56) mdd: (man 56) prn: 57]	[noun: (prize 56) cat: snp sem: def sg fnc: deserve prn: 57]	[verb: get cat: decl sem: pres arg: man prize prn: 56]	[noun: prize cat: snp sem: def sg fnc: get mdr: (want 58) prn: 56]	[noun: (man 56) cat: snp sem: def sg fnc: want prn: 58]	[verb: want cat: v sem: pres arg: (man 56) # mdd: (prize 56) prn: 58]
--	---	--	--	---	---	--

11.6 Coreference in Adverbial Sentential Modifiers

11.6.1 LANGACKER-ROSS CONSTRAINT IN ADVERBIAL SUBCLAUSES

1. LH' Coreferent noun in lower clause (L) precedes pronoun in matrix (H')
When *Mary* returned *she* kissed John.
2. H'L Pronoun in matrix (H') precedes non-coref. noun in lower clause (L)
% *She* kissed John when *Mary* returned.
3. L'H Pronoun in lower clause (L') precedes coreferent noun in matrix (H)
When *she* returned *Mary* kissed John.
4. HL' Coreferent noun in matrix (H) precedes pronoun in lower clause (L')
Mary kissed John when *she* returned.

11.6.2 Adverbial modifier sentence: Pronoun in higher clause

1. **LH'**: When *Mary* returned *she* kissed John.
2. **H'L**: % *She* kissed John when *Mary* returned.

(i) semantic relations graph (SRG)

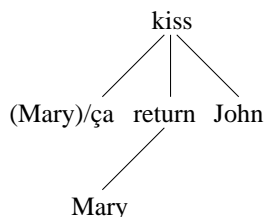

(ii) signature

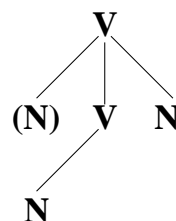

(iii) numbered arcs graph (NAG)

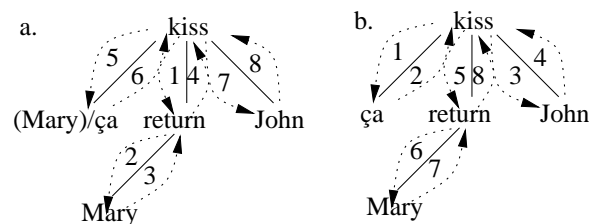

(iv) surface realization

- a. 1 2 3 4-5 6 7 8
 When Mary returned she kissed John .
- b. 1 2 3 4-5 6 7 8
 % She kissed John when Mary returned .

11.6.3 Representing variant 1 as a set of proplets

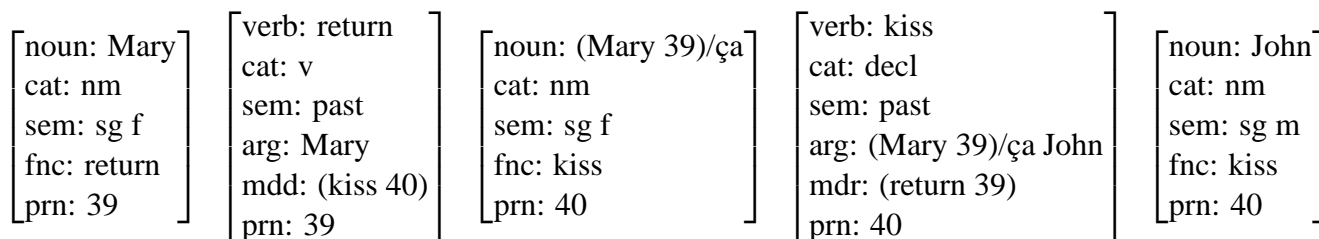

11.6.4 Adverbial modifier sentence: Pronoun in lower clause

3. **L'H**: When *she* returned *Mary* kissed John.

4. **HL'**: *Mary* kissed John when *she* returned.

(i) *semantic relations graph (SRG)*

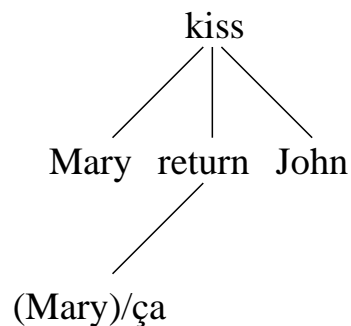

(iii) *numbered arcs graph (NAG)*

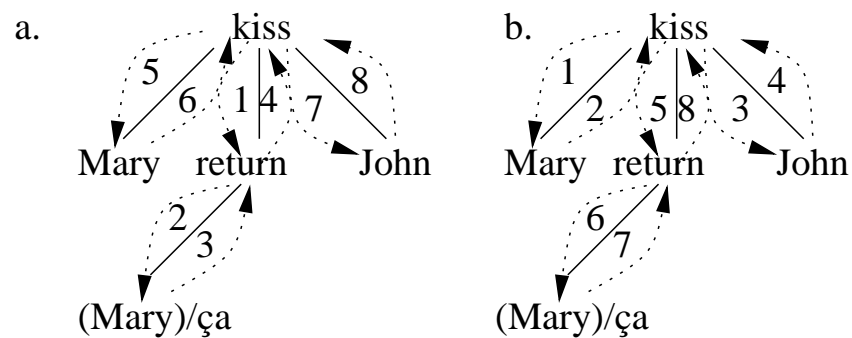

(ii) *signature*

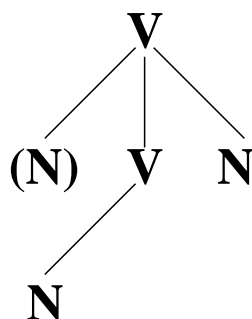

(iv) *surface realization*

a.	1	2	3	4-5	6	7	8
	When	she	returned	Mary	kissed	John	.
b.	1	2	3	4-5	6	7	8
	Mary	kissed	John	when	she	returned	.

Part III.

Final Chapter

12. Conclusion

12.1 Level of Abstraction

12.1.1 The Equation Principle of Database Semantics

1. The more realistic the reconstruction of natural cognition, the better the functioning of the artificial model.
2. The better the functioning of the artificial model, the more realistic the reconstruction of natural cognition.

12.2 Evolution

12.2.1 Consecutive vs. Concurrent Hypothesis

- a. Consecutive hypothesis:
language ability evolves from non-language abilities

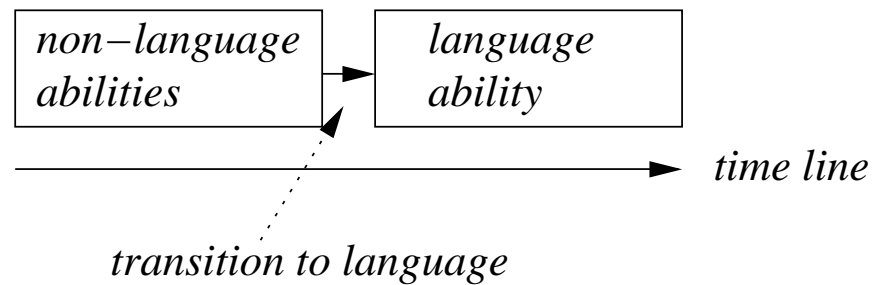

- b. Concurrent hypothesis:
language ability evolves from communication ability

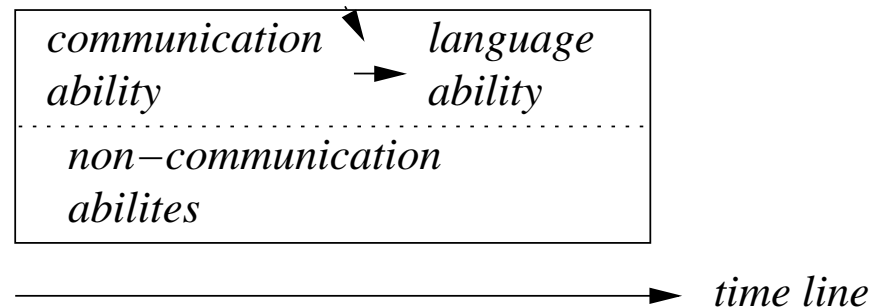

12.3 Semantics

12.3.1 Predicate calculus analysis of Every man loves a woman.

reading 1: $\forall x[\text{man}'(x) \rightarrow \exists y[\text{woman}'(y) \ \& \ \text{love}'(x, y)]]$

reading 2: $\exists y[\text{woman}'(y) \ \& \ [\forall x[\text{man}'(x) \rightarrow \text{love}'(x, y)]]]$

12.3.2 DBS analysis of Every man loves a woman.

noun: man	verb: love	woman
cat: snp	cat: decl	cat: snp
sem: exh pl	sem: pres	sem: indef sg
fnc: love	arg: man woman	fnc: love
prn: 23	prn: 23	prn: 23